

ORION 225 HCCA INSTALLATION MANUAL



Quick Links

- [225 Hcca Description and Equipment Supplied](#)
- [250 Hcca Description and Equipment Supplied](#)
- [425 Hcca Description and Equipment Supplied](#)
- [Power and Ground Connections](#)
- [Speaker Connections](#)

Table of Contents

- [Table of Contents](#)
- [225 HCCA Description and Equipment Supplied](#)
- [250 HCCA Description and Equipment Supplied](#)
- [425 HCCA Description and Equipment Supplied](#)
- [Orion Accessories, Description](#)
- [Orion Cable Assemblies](#)
- [Using Existing 6x9 Speakers](#)
- [Use of a Crossover Module.9](#)
- [Use of a Bridging Module](#)
- [ORION HCCA Use of a 30 dBLP Low Pass Filter](#)
- [Use of a 30 dBHP High Pass Filter](#)
- [Killer Systems](#)
- [Use of a 4-Channel Power Amplifier 425 HCCA](#)
- [Mounting the Amplifier](#)
- [Power and Ground Connections](#)
- [Speaker Connections](#)
- [System Adjustments](#)
- [Other ManualsLib Projects](#)

ORION Car Audio Power Amplifiers (High Current Output)

Models 225 HCCA, 250 HCCA and 425 HCCA

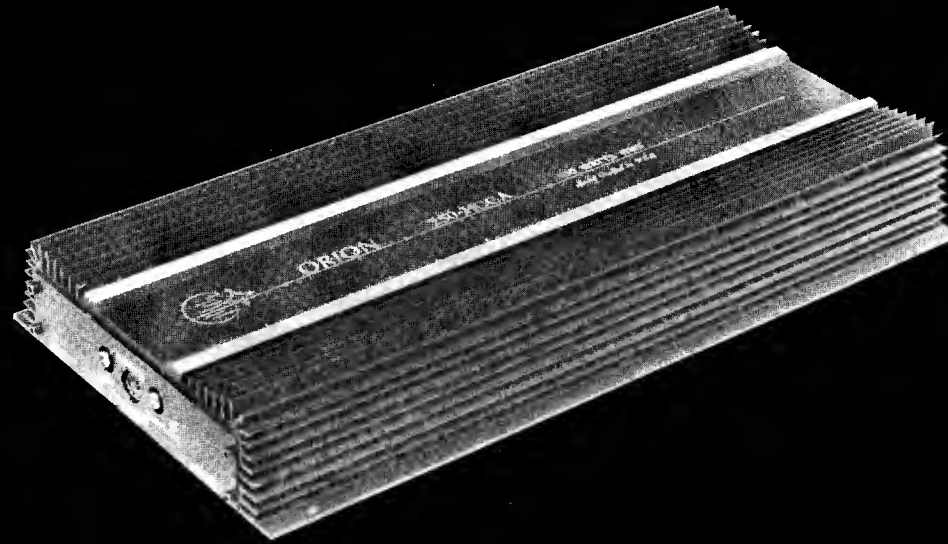

*Built in the U.S.A. from the ground up specifically
for high performance car stereo systems*



When Only The Best Will Do

INTRODUCTION

You have purchased the finest car audio power amplifier available on the market. ORION amplifiers really do set new standards for performance and reliability. They are superbly crafted and precision calibrated. If you install each amplifier properly with careful attention to all the details covered in this manual, you will be astonished with the quality of sound and you will have an audio system that you can be proud of and enjoy for many years.

- The HCCA series amplifiers incorporate high output current, enhancing audio performance and improving sonic quality.
 - All ORION amplifiers are built in the U.S.A. from the ground up specifically for high performance car stereo systems. *Car stereo systems are our only business.*
 - All ORION amplifiers and accessories are manufactured to exacting military standards. Extensive testing and burn-in makes for super reliability in even the toughest situations.
 - Each amplifier contains a ± 15 volt power supply which also services ORION accessories ("phantom power"). This ensures maximum dynamic performance from all accessories while maintaining optimum ground isolation to minimize potential engine noise. A POWER ON indicator light is included.
 - Variable input sensitivity (gain adjust) allows use with most radios and decks.
- Optically isolated remote turn-on circuit isolates the radio or deck from the amplifier.
 - FET switched 40 dB audio attenuator reduces turn-on/turn-off "thump".
 - Parallel RCA and DIN inputs provide considerable versatility for interconnections.
 - 6 Hz high pass filter eliminates dc offset.
 - A wide variety of accessories are available for flexibility in designing overall audio systems (refer to page 6).

This manual covers the following ORION HCCA amplifiers:

225 HCCA (refer to page 3)

250 HCCA (refer to page 4)

425 HCCA (refer to page 5)

Table of Contents

225 HCCA Description and Equipment Supplied . . .	3
250 HCCA Description and Equipment Supplied . . .	4
425 HCCA Description and Equipment Supplied . . .	5
Orion Accessories, Description	6, 7
Orion Cable Assemblies	7
Using Existing 6x9 Speakers	8
Use of a Crossover Module	9
Use of a Bridging Module	10
Use of a 30 dB LP Low Pass Filter	10
Use of a 30 dB HP High Pass Filter	10
Killer Systems	10
Use of a 4-Channel Power Amplifier 425 HCCA . . .	10
Mounting the Amplifier	26
Power and Ground Connections	27
Speaker Connections	34
System Adjustments	35

ORION 225 HCCA

High Current Stereo Power Amplifier

50 Watts RMS

EQUIPMENT SUPPLIED

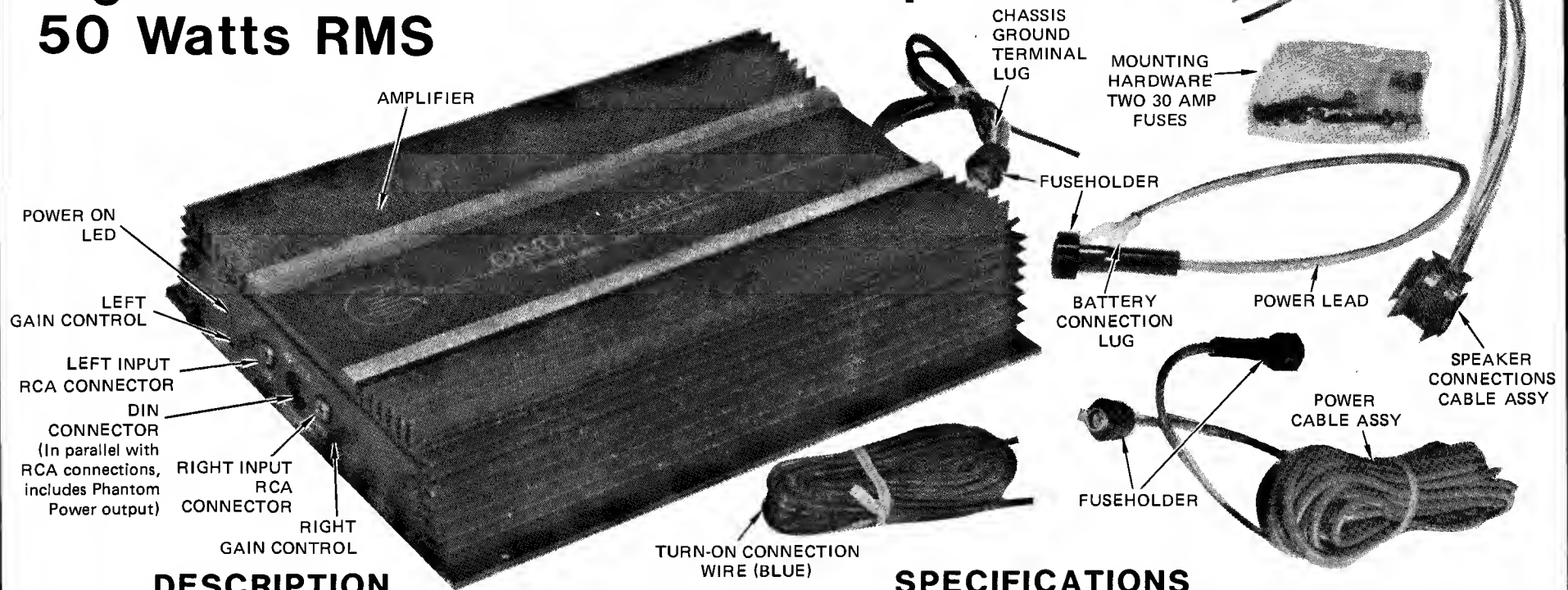

DESCRIPTION

The ORION 225 HCCA is a stereo power amplifier that includes all the features of the larger ORION amplifiers and provides 25 watts RMS output per channel, or 100 watts at 4 ohms or 200 watts at 2 ohms when bridged using ORION Bridging Module 400 BDG (refer to page 6).

The 225 HCCA can be used to greatly improve existing factory sound systems utilizing 6 x 9 speakers. In customized systems, the 225 HCCA can be used to drive tweeters and mid-range speakers in multiple amplifier applications.

SPECIFICATIONS

Output Power Per Channel with both channels driven into 4 ohms @ 12 Vdc	25 WRMS
Distortion:	
Typical	0.005%
Maximum	0.03%
Frequency Response	6 Hz to 50 KHz ±0.5 dB
Signal to Noise Ratio	112 dB
Input Sensitivity	150 mV to 2 Vrms
Output Impedance	0.5 ohm to 16 ohms

Input Impedance	10K ohms
Remote Turn-on Current	50 mA
Current Consumption:	
@ No Signal	250 mA
@ Maximum Output	35 Amps
Voltage Requirements	10V to 16V
Damping Factor	Greater than 500
Output Section Slew Rate	30V per microsecond
Stereo Separation	80 dB
Overall Dimensions	11 x 8.5 x 2.25 inches

ORION 250HCCA

High Current Stereo Power Amplifier

100 Watts RMS

EQUIPMENT SUPPLIED

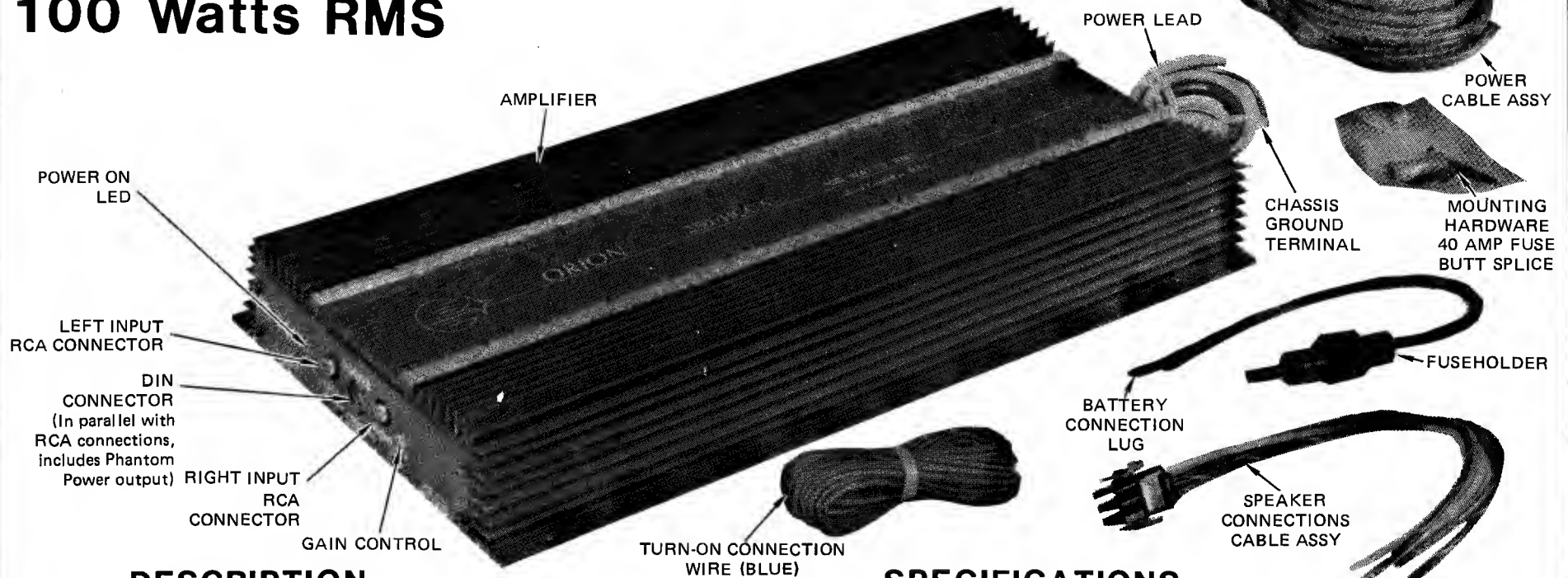

DESCRIPTION

The ORION 250 HCCA is an excellent choice for easy listening systems where you want full range with smooth highs and rich, tight bass. The amplifier is also ideal for handling tweeters and mid-range speakers in competition systems. Because of the high current output and low impedance characteristics, it is the answer to adding additional speakers in parallel.

The 250 HCCA provides 50 watts RMS of distortion-free power per channel or 400 watts at 2 ohms when bridged using the ORION Bridging Module 400 BDG (see page 6).

SPECIFICATIONS

Output Power Per Channel with both channels driven into 4 ohms @ 12 Vdc	50 WRMS
Distortion:	
Typical	0.005%
Maximum	0.03%
Frequency Response	6 Hz to 50 KHz \pm 0.5 dB
Signal to Noise Ratio	112 dB
Input Sensitivity	150 mV to 2 Vrms
Output Impedance	1 ohm to 16 ohms

Input Impedance	10K ohms
Remote Turn-on Current	50 mA
Current Consumption:	
@ No Signal	600 mA
@ Maximum Output	50 Amps
Voltage Requirements	10V to 16V
Damping Factor	Greater than 500
Output Section Slew Rate ...	30V per microsecond
Stereo Separation	80 dB
Overall Dimensions	17 x 8.5 x 2.25 inches

ORION 425 HCCA

Four Channel High Current Power Amplifier

100 Watts RMS

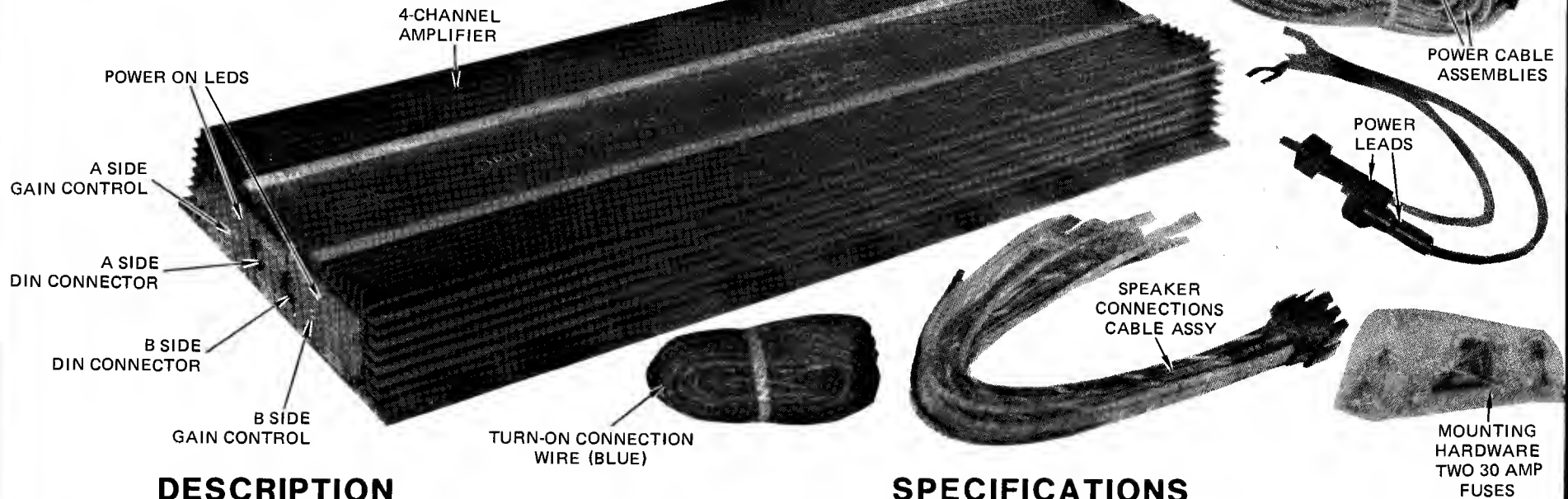

DESCRIPTION

The 425 HCCA contains two pairs of stereo amplifiers with a separate power supply for each pair of amplifiers. It has been designed for installations where space limitations preclude the use of separate stereo amplifiers. Each of the four channels supplies 25 watts RMS or 400 watts at 1 ohm when bridged using ORION Bridging Module 400 BDG (refer to page 6).

As shown above, two power cable assemblies and two power leads are provided (one for each of the internal power supplies). Each pair of amplifiers must be grounded separately as shown on pages 30 and 31. A single blue turn-on wire is used to turn on all four channels.

SPECIFICATIONS

Output Power Per Channel
with all channels driven
into 4 ohms @ 12 Vdc 25 WRMS

Distortion:
Typical 0.005%
Maximum 0.03%

Frequency Response 6 Hz to 50 KHz ±0.5 dB

Signal to Noise Ratio 112 dB

Input Sensitivity 150 mV to 2 Vrms

Output Impedance 0.5 ohm to 16 ohms

Input Impedance 10K ohms

Remote Turn-on Current 50 mA

Current Consumption:
@ No Signal 500 mA
@ Maximum Output 70 Amps

Voltage Requirements 10V to 16V

Damping Factor Greater than 500

Output Section Slew Rate 30V per microsecond

Stereo Separation 80 dB

Overall Dimensions 22 x 8.5 x 2.25 inches

ORION ACCESSORIES



300 PRQ PRE-AMPLIFIER EQUALIZER

The ORION 300 PRQ provides pre-amplification plus three bands of equalization (40 Hz cut and boost, 180 Hz cut and boost, and 15 kHz cut and boost). Designed primarily to help compensate for speaker deficiencies, eliminate distortion, and boost range. Input is independently adjustable from 30 mV to 3V RMS. Includes a high-quality volume control. Powered by "phantom power" provided by any ORION amplifier or an ORION PPS 100 Phantom Power Supply.



600 EQM EQUALIZER MODULE

Audiophile grade equalization for well set-up car audio systems. Features high quality, troublefree rotary controls. The 600 EQM provides six equalization points (30 Hz, 90 Hz, 180 Hz, 2 kHz, 5 kHz, and 15 kHz. Input sensitivity is adjustable. Powered by "phantom power" provided by any ORION amplifier or an ORION PPS 100 Phantom Power Supply.



400 BDG BRIDGING MODULE

The ORION 400 BDG Bridging Module is used to convert two stereo channels to mono to increase output power 4 times. Generally used to convert lows (bass) to mono while leaving the midranges and highs in stereo.

Four modes of operation.

1. Mixed mono output.
 2. Summed mono output.
 3. Bridged stereo right.
 4. Bridged stereo left.
- Powered by "phantom power" provided by any ORION amplifier or an ORION PPS 100 Phantom Power Supply.

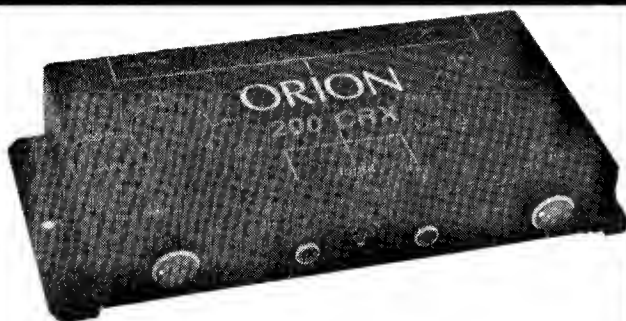

200 CRX ACTIVE CROSSOVER

The ORION 200 CRX is a highly efficient, continuously adjustable, 12 dB per octave, 2-way crossover. Designed for use in multi-amplifier systems with some amplifiers dedicated to the low frequencies and some amplifiers dedicated to the high and midrange frequencies. Independent adjustment of low pass and high pass frequencies from 50 Hz to 5 kHz. Total frequency response is 10 Hz to 50 kHz. Extremely versatile—capable of driving up to 20 amplifiers. "Phantom power" is supplied by any ORION amplifier or by an ORION PPS 100 Phantom Power Supply.



300 CRX 3-WAY ACTIVE CROSSOVER

The ORION 300 CRX is a versatile 12 dB per octave 3-way crossover. Designed for use in multi-amplifier systems with some amplifiers dedicated to only the high frequencies, some amplifiers dedicated to only the mid-range frequencies, and some amplifiers dedicated to only the low frequencies. Crossover frequencies are continuously adjustable between 50 Hz and 5 kHz on all bands. Total frequency response is 10 Hz to 50 kHz. "Phantom power" is supplied by any ORION amplifier or by an ORION PPS 100 Phantom Power Supply.

500 PMQ PARAMETRIC EQUALIZER

Outstanding flexibility. Allows you to change the frequency of boost and cut. The ORION 500 PMQ Parametric Equalizer features five dual controls—outer knob for selecting the frequency band, and an inner knob for controlling boost or cut for each band. Frequency bands are 30 to 75 Hz, 50 to 150 Hz, 500 to 1.5 kHz, 1.5 to 5 kHz, and 5 to 15 kHz. Boost and cut for each frequency band is 10 dB up or 10 dB down. The EQ curve is fixed. Includes a high-quality volume control. Gain adjustment is 30 mV to 3V RMS. Powered by "phantom power".





30 DBLP LOW PASS FILTER and 30 DBHP HIGH PASS FILTER

When you want pure sound, add a 30 DBLP Low Pass Filter or a 30 DBHP High Pass Filter (or both) to your system. 30 dB per octave low pass or high pass. Cutoff frequency from 48 Hz to 6 kHz through the use of two plug-in chips. The 30 DBLP Low Pass Filter is used to keep the midrange and high frequencies out of your subwoofers, correct for mismatched speakers, eliminate speaker box resonance problems, and remove distortion. The 30 DBHP High Pass Filter is used to make your tweeters sound more lively. Isolated audio ground to prevent audio ground loops and eliminate engine noise. Powered by any ORION amplifier or an ORION PPS 100 Phantom Power supply.

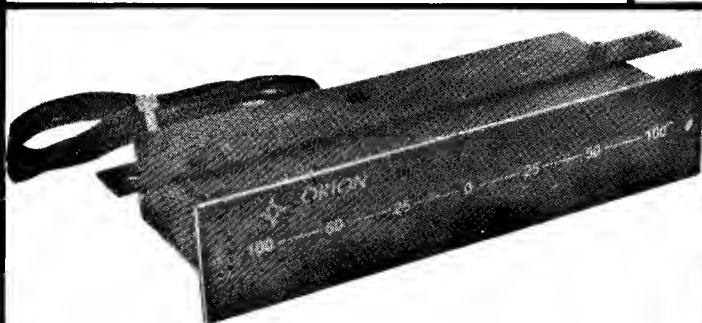

100 LED DISPLAY

Ideal for input monitoring to avoid overdriving. 12V dual 10 segment display. Continuously adjustable for fine tuning. Does not add audio distortion in the signal path. Can be mounted under the dash or in the dash.

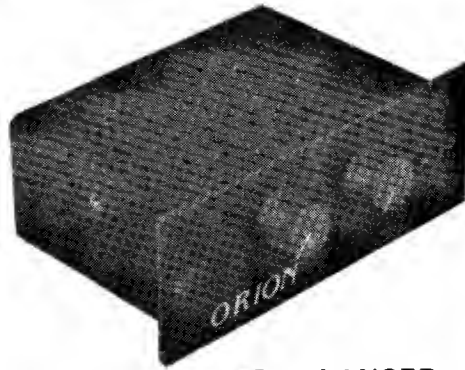

200 DAB DUAL AMP BALANCER

The ORION 200 DAB Dual Amp Balancer allows individual level adjust for multi-amplifier use. You can crank up the front speakers and tone down the rear speakers, or the other way around. For use with decks and radios with or without fader controls. A switch is provided on the rear of the unit for selecting dual or single input terminations. No operating power required.



PPS 100 PHANTOM POWER SUPPLY

Provides +15 and -15V dc phantom power for use with all ORION accessories. DIN and RCA output connectors. Remote turn on wire. Pulls minimal current so is not a factor in overall power usage for audio system.

ORION CABLE ASSEMBLIES

A large variety of top quality ORION cable assemblies are available through your dealer, as follows:

5 PIN DIN TO DIN

Lengths: 6 inches, 1, 2, 3, 4, 5, 6, 10 and 20 feet

5 PIN DIN TO RCA

Lengths: 1, 2, 4, 10 and 20 feet

Order by description. Prices are reasonable and cable assemblies are shipped the same day the order is received.

Speaker connections cable assemblies and power wire are also available.

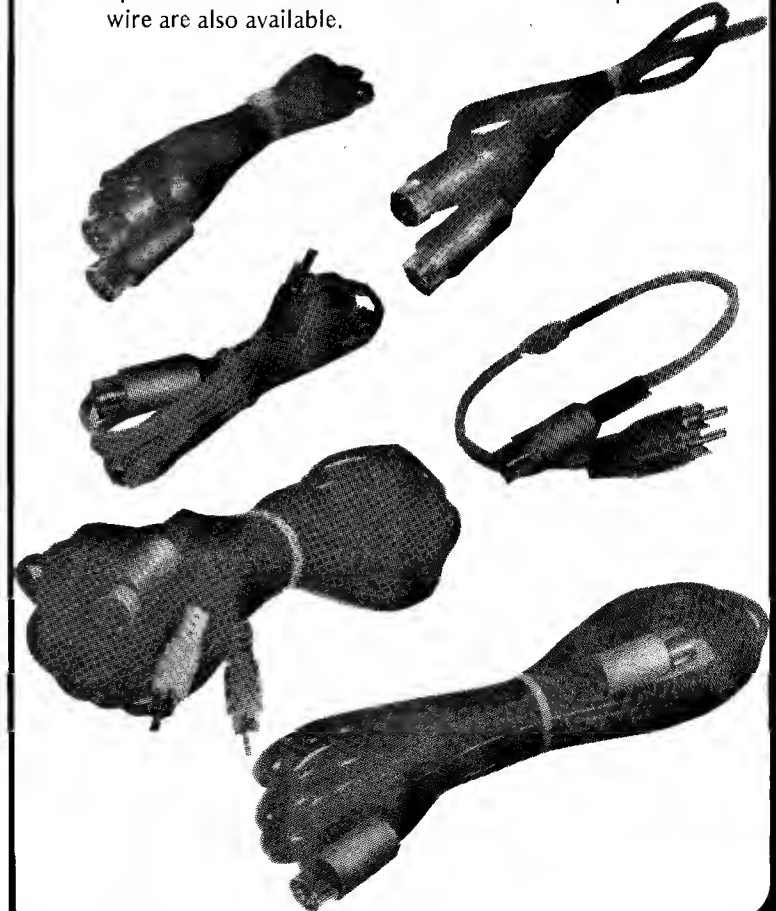

PLANNING YOUR CAR AUDIO SYSTEM

It is important that you decide what you are trying to achieve. Car audio systems can vary from merely upgrading your existing factory installation to multi-amplifier systems that include equalizers, bridging modules, crossover modules, low pass filters, high pass filters, and a variety of speakers. This section contains the simple approaches to audio system design to the very complex. By studying the diagrams, you will see that you can start with a relatively simple system that can gradually grow by adding accessories and additional amplifiers.

A. USING EXISTING SPEAKERS

If you want a good performance system without having to install special speakers, a single 225 HCCA amplifier will do an excellent job for you. A basic single amplifier system is shown in figure 1.

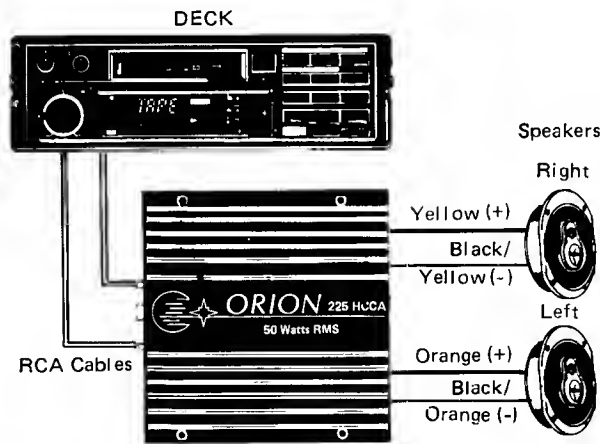
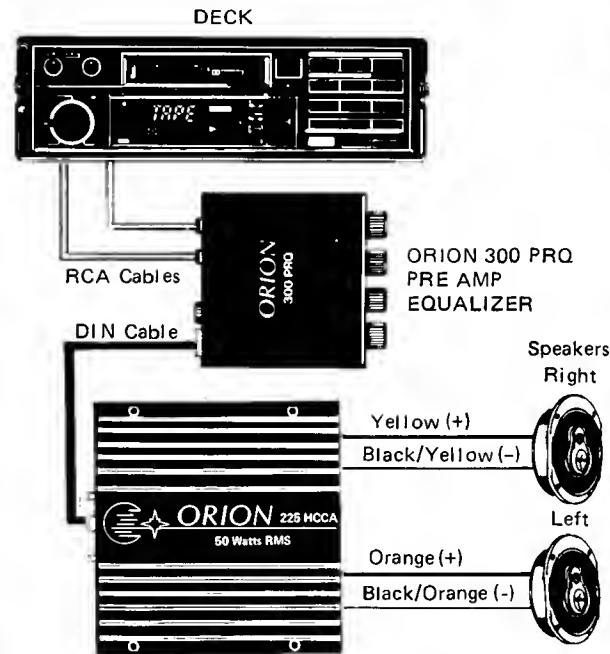

Figure 1. Basic Single-Amplifier System Using Existing Speakers

(1) **Adding Equalization.** To improve the system even more, you could add an equalizer, such as an ORION 300 PRQ Pre Amp Equalizer, 600 EQM Equalizer, or 500 PMQ Parametric Equalizer (see page 6). The equalizer would be inserted in the system between the deck and the amplifier as shown in figure 2.



"Phantom Power (+15V & -15V) is supplied to all ORION accessory modules by the amplifier through the DIN cable.

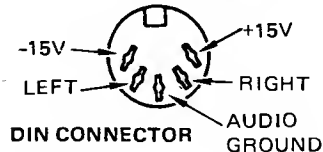

Figure 2. Basic Single-Amplifier System Using an Equalizer and Existing Speakers

(2) **Front and Rear Speakers.** If your car is equipped with front and rear speakers, you will want to use a separate amplifier for each pair of speakers as shown in figure 3. A single 4-channel 425 HCCA could also be used for this system (see figure 16).

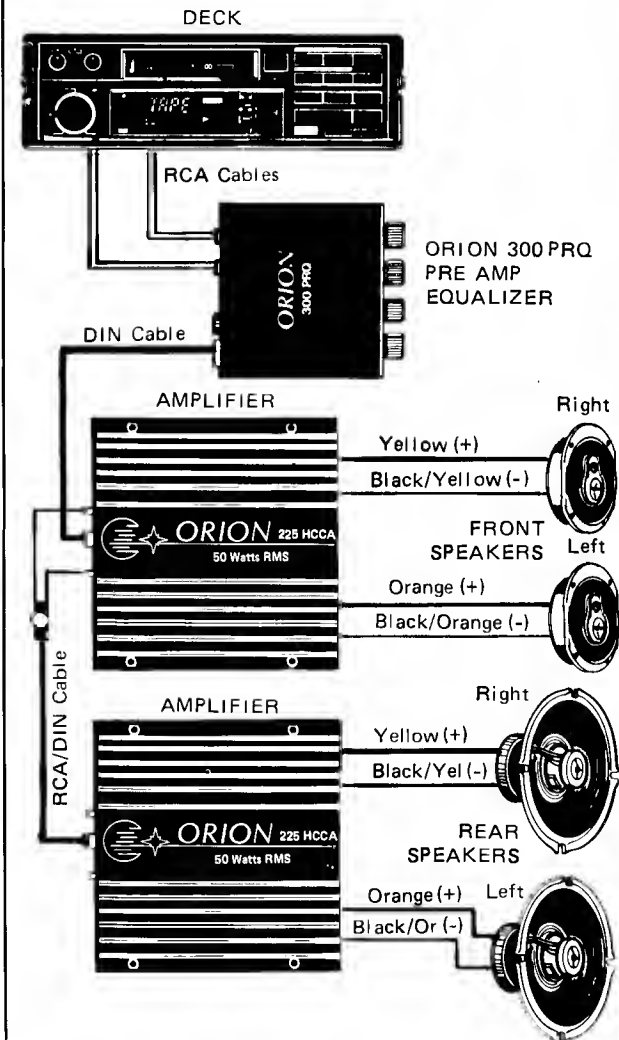

Figure 3. Basic Two-Amplifier System Using Equalizer and Existing Front and Rear Speakers

(3) Adding Subwoofers. For added punch, you could add a couple of subwoofers to the system as shown in figure 4. This will give you the most coherent and natural sound. In this system, a pair of mid-range/tweeter speakers are located in the front (usually in the top of the dash), and a midrange/tweeter speaker is located in each rear door or side panel. The subwoofers are installed in the rear. *This does not mean that the passengers seated in the rear will be overcome by the bass. Low frequency sound waves tend to wrap around the interior such that they are perceived as coming from all directions.*

IMPORTANT NOTE: At this point, you must determine if your car has enough power to supply the needs of the engine, lighting system, and air conditioning system as well as the audio system. An existing car electrical system can generally handle up to four 225 HCCA or up to three 250 HCCA amplifiers. If you plan to use more, or larger amplifiers, refer to the discussion on "power requirements" on page 29.

(4) Adding Crossover or Bridging Modules. An existing speaker system can also include a crossover module and/or bridging module similar to the custom systems described in paragraphs B through F below.

B. USE OF A CROSSOVER MODULE

An ORION 200 CRX Active Crossover or 300 CRX 3-Way Active Crossover can be one of the most important additions to your car audio system. It lets you adjust the highs and midranges to where they sound best, then independently adjust the lows to where they sound great. The 200 CRX Active Crossover contains a low pass filter section (for your subwoofers) and a high pass filter section (for midranges and tweeters). The 300 CRX 3-Way Active Crossover contains a low pass filter section for the sub-

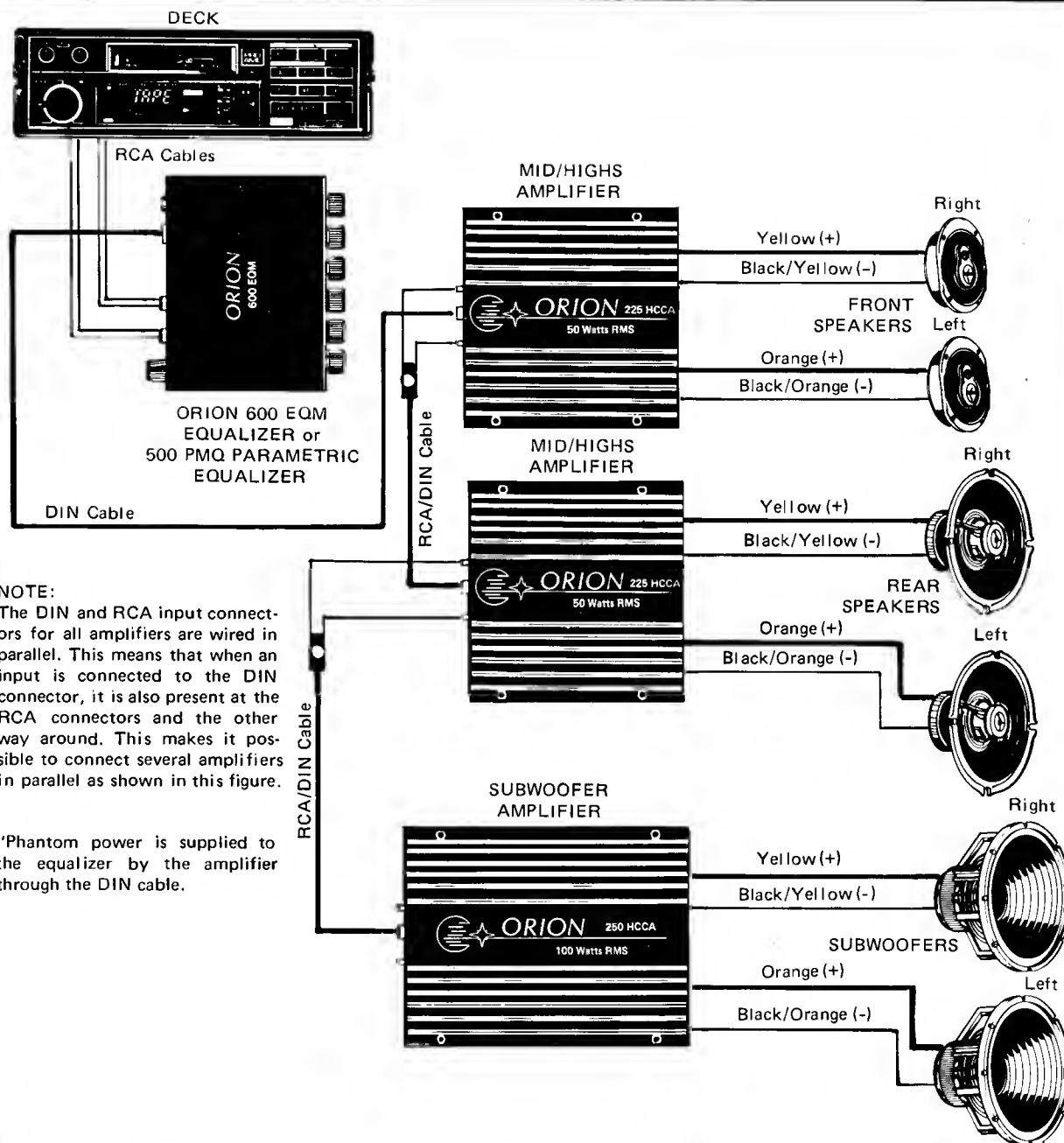

Figure 4. Typical Way of Adding Subwoofers to a System

woofers, a bandpass filter section for the midranges, and a high pass filter section for the tweeters.

(1) **Use of 200 CRX Active Crossover.** This crossover module can be used in a variety of ways: It could be added to the simple two-amplifier system as shown in figure 5. It could also be used in a 3-amp system as shown in figure 6. Note in figure 6 that an ORION 200 DAB Dual Amp Balancer has been added to control the level of sound that comes from each section of the car audio system.

(2) **Use of 300 CRX 3-Way Active Crossover.** For even better control, use the 300 CRX as shown in figure 7. This will give you separate control of the low frequencies, midrange frequencies, and high frequencies.

C. USE OF A BRIDGING MODULE

The ORION 400 BDG Bridging Module can turn your amplifiers into real power houses. Bridging an amplifier converts a two-channel amplifier into a single channel amplifier (mono. output). Each internal channel "sees" half of the total impedance of the load. For example, when using 4-ohm speakers, each channel in the amplifier sees half of this 4 ohms or 2 ohms. If you were using a 225 HCCA amplifier, which delivers 25 watts per channel, the output delivered to each speaker will be 100 watts when bridged, thus a 4 times increase in output.

The 400 BDG Bridging Module can be used in the summed mono mode, mixed mono mode, or bridged stereo right and left (see figure 8).

(1) **Summed Mono Mode.** In the summed mono mode (true mono), the bridging module is generally used to drive the subwoofers in mono (bridged power).

This application is very practical since in stereo recordings the kick drums and bass are centered between stereo right and stereo left, along with the other rhythm instruments. Always keep in mind that it takes much more power to drive low fre-

quencies than high frequencies.

A typical 3-amplifier system using a bridging module is shown in figure 9.

(2) **Mixed Mono Mode.** If you are installing a single amplifier system, the mixed mono mode can be used as shown in figure 10. This mode is used to provide more power to the subwoofers while maintaining stereo left and right. In this system, the 400 BDG Bridging Module accepts the stereo inputs and turns one channel over 180° (inverts the channel). Both channel outputs of the amplifier are now connected to the subwoofer with the inverted channel being used as the *negative* input. This works because the two channels are 180° out-of-phase.

The left mid/high speaker is connected normally, but the connections to the right mid/high speaker must be *turned over* to retain the stereo effect. This means that the yellow lead now becomes the *negative* lead and the black/yellow lead becomes the *positive* lead.

CAUTION: *The speakers must never be grounded to the car chassis or body. To do so will cause severe noise problems and, in the case of bridging, cancel out the two-phase operation.*

(3) **Bridged Stereo Right and Left.** This application is used when you want to maintain the stereo effect while increasing the output power of your amps by 4 times. A typical system is shown in figure 11.

D. USE OF 30 DBLP LOW PASS FILTER

NOTE: *Low pass and high pass filters can only be used effectively in multi-amp systems such as shown in figures 12, 13 and 14.*

If you are using mismatched subwoofers, or having speaker box resonance problems, or experiencing bass distortion, consider using a 30 DBLP Low Pass Filter as

shown in figure 12. This filter will keep the midrange and high frequencies out of your subwoofers. The cut-off frequency is selected by plugging in two resistive chips. This means that if you install 80 Hz chips in the filter, only frequencies of 80 Hz and below will pass through to your subwoofers and frequencies above 80 Hz will be blocked.

E. USE OF 30 DBHP HIGH PASS FILTER

The 30 DBHP High Pass Filter is used primarily to make your tweeters sound more lively. Keep in mind that it is the low frequencies that hurt the tweeter performance. A typical application of a high pass filter is shown in figure 13. The high pass filter produces large amounts of attenuation (reduction in power) to frequencies *below* the cutoff frequency and no attenuation to frequencies *above* the cutoff frequency. This means that if you install 4 kHz chips in the filter, only frequencies of 4 kHz and above will pass through to your tweeters and frequencies below 4 kHz will be blocked.

F. "KILLER SYSTEMS"

Figure 14 shows a "Killer System" that uses an ORION 200 CRX Active Crossover to separate the highs from the lows. A 30 DBHP High Pass Filter is used to enhance the performance of separate pair of tweeters. All subwoofers are driven from the SUMMED MONO output of a 400 BDG Bridging Module. A 30 DBLP Low Pass Filter is used to control the lows to a selected set of subwoofers.

Figure 15 shows a "Killer System" that uses an ORION 300 CRX Active Crossover to separate the highs, midranges and lows. This approach offers the best overall control of the speakers and makes it possible to use several amplifiers connected in parallel.

G. USE OF 4 CHANNEL POWER AMPLIFIER 425 HCCA

Figures 16 and 17 show typical systems using 425 HCCA Amplifiers.

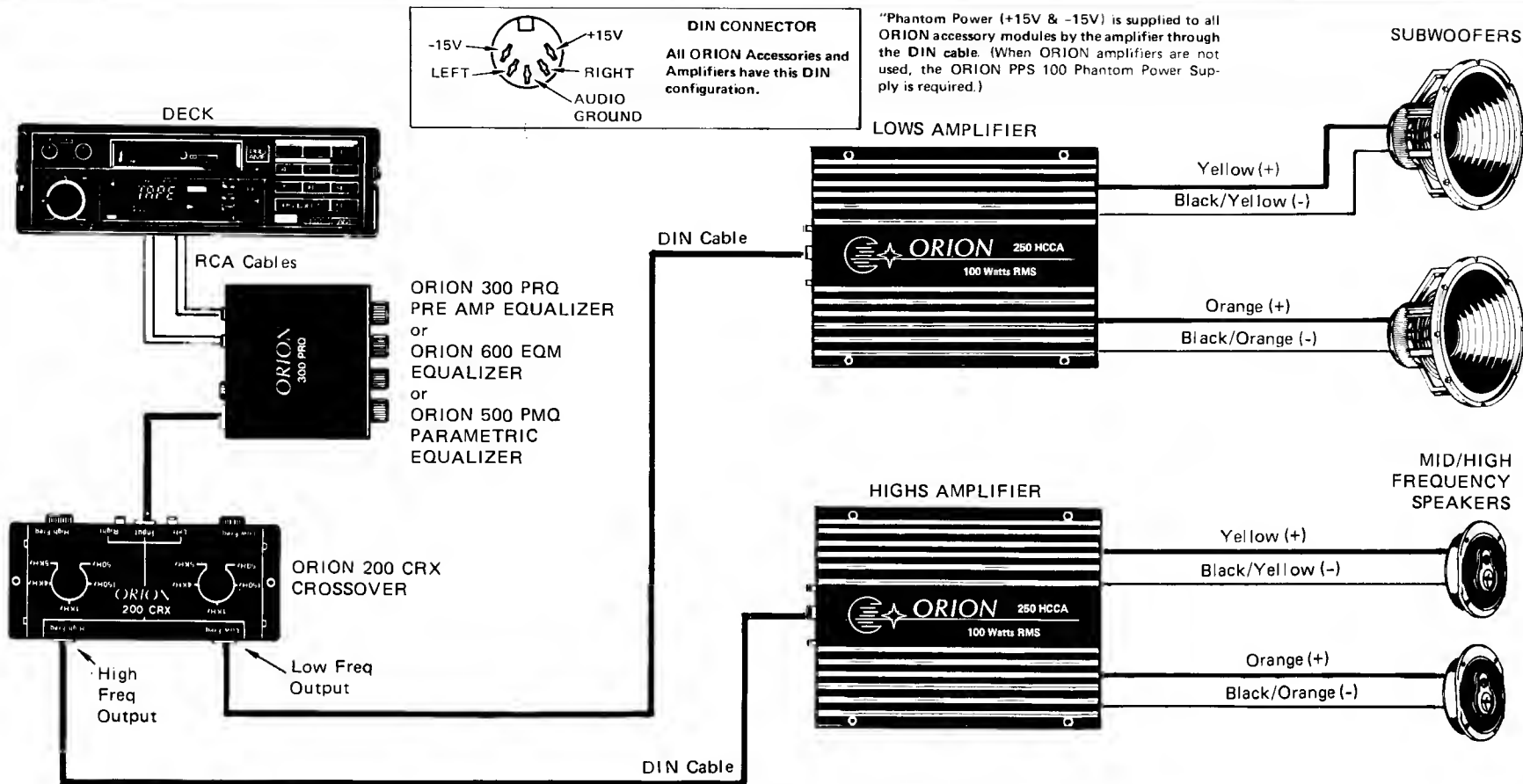

This is a simple two-amplifier system using a 200 CRX Active Crossover for better control of the frequencies applied to the speakers. The LOW FREQ output is connected to the lows amplifier to drive the subwoofers, and the HIGH FREQ output is connected to the highs amplifier for driving the midrange and highs speakers.

This allows you to carefully balance the higher and midrange frequencies with the lows. In practice, overlapping the crossover point slightly results in smooth transitions of sounds delivered to the speakers. For example, the cutoff frequency for lows could be adjusted to 400 Hz. This would mean that all frequencies

below 400 Hz would be passed to the lows amplifier at 100% power. The attenuation (reduction in power) is 12 dB which is a reduction in power of about 90%. An octave is a doubling of frequency so that at 800 Hz only about 10% of the power would go to the subwoofers. In this example, the high output would be adjusted to pass only frequencies above 300 Hz. This would give you about 100 Hz overlap. Then you could make slight adjustments to provide the sound that pleases you the most.

This system could be designed using two 225 HCCA 2-channel amplifiers (25 watts per channel) or a 425 HCCA 4-channel amplifier. For added power, you

could choose two 250 HCCA amplifiers (50 watts per channel).

For installation, connections and adjustments, refer to pages 26 through 35.

Figure 5. Two-Amplifier System Using an ORION 200 CRX Active Crossover

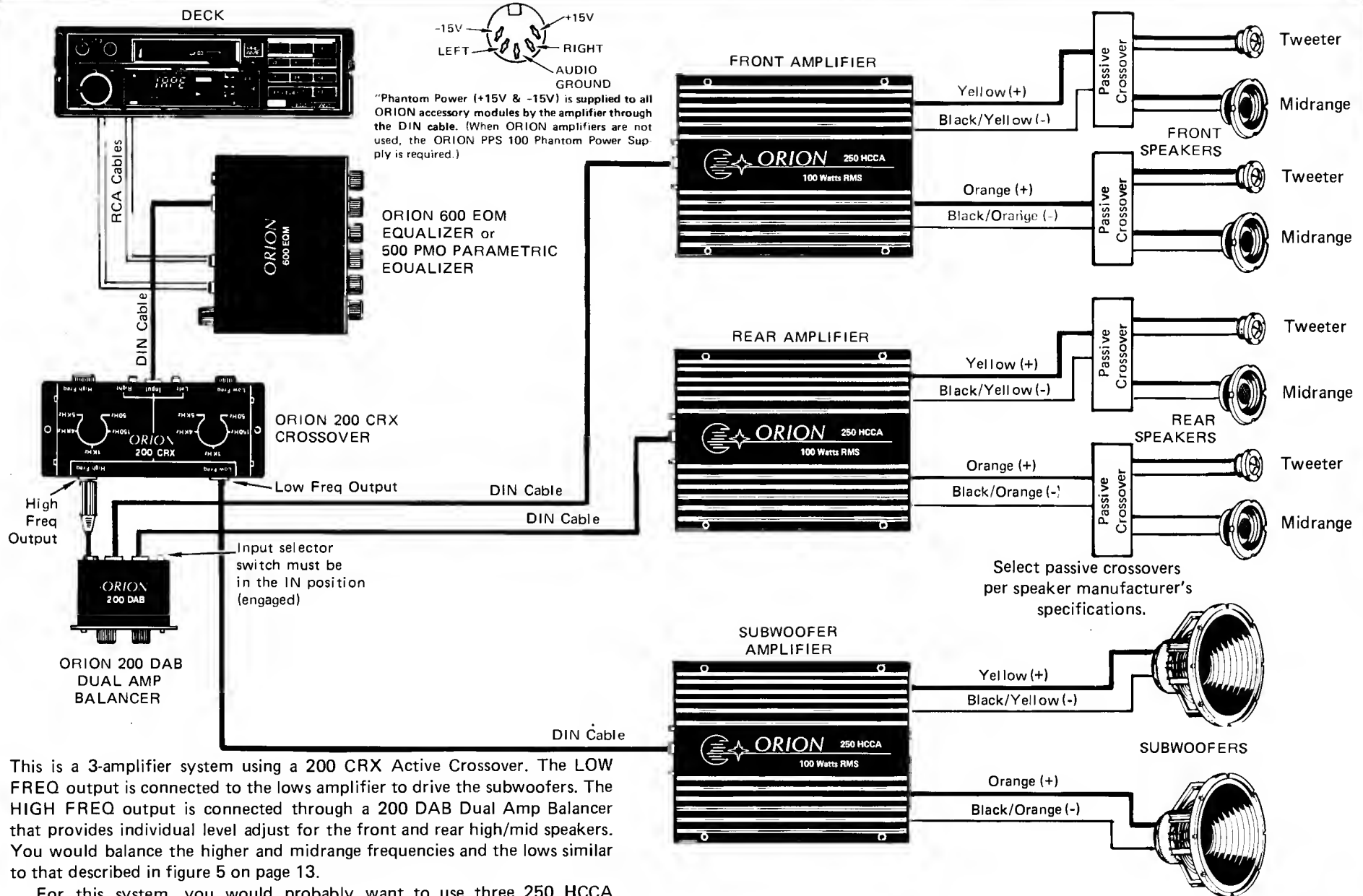

This is a 3-amplifier system using a 200 CRX Active Crossover. The LOW FREQ output is connected to the lows amplifier to drive the subwoofers. The HIGH FREQ output is connected through a 200 DAB Dual Amp Balancer that provides individual level adjust for the front and rear high/mid speakers. You would balance the higher and midrange frequencies and the lows similar to that described in figure 5 on page 13.

For this system, you would probably want to use three 250 HCCA 2-channel amplifiers (50 watts per channel). You could also build a satisfactory system using two 225 HCCA 2-channel amplifiers to drive the mid-range speakers and tweeters and a 250 HCCA to drive the subwoofers. You might also use a 425 HCCA 4-channel amplifiers to drive the midrange and tweeters and a 250 HCCA to drive the subwoofers.

For installation, connections and adjustments, refer to pages 26 through 35.

Figure 6. Three-Amplifier System Using 200 CRX Active Crossover and 200 DAB Dual Amp Balancer

"Phantom Power (+15V & -15V) is supplied to all ORION accessory modules by the amplifier through the DIN cable. (When ORION amplifiers are not used, the ORION PPS 100 Phantom Power Supply is required.)

This is a 3-amp system using a 300 CRX 3-Way Active Crossover. The 300 CRX makes it possible to use separate amplifiers for the tweeters, midrange speakers, and subwoofers.

Less power is required to drive the high frequencies to the tweeters than that required for midrange and low frequencies, so this diagram shows a 225 HCCA (25 watts per channel) being used for the tweeters.

The midrange and subwoofer amplifiers could be selected according to your output power requirements and space availability. (If you decide to use three 250 HCCA's, you may have to add an additional battery. Refer to page 27.)

The high frequency output of the 300 CRX is an adjustable high pass filter. A common adjustment would be to pass all frequencies 4000 Hz and above to the tweeters. The midrange output is a bandpass filter with separate controls for adjusting the low end and the high end. A common adjustment might be to pass all frequencies between 100 Hz and 4100 Hz, but the settings are dependent on the settings of the high and low frequency outputs. There should be a certain amount of overlapping. The low frequency output is an adjustable low pass filter. A common adjustment would be to pass all frequencies below 180 Hz. The actual settings of the frequencies depend on what sounds best in your system.

If you intend to use this system, we highly recommend that you 4-times the output of your subwoofer amplifier by adding a 400 BDG Bridging Module as shown in figure 9.

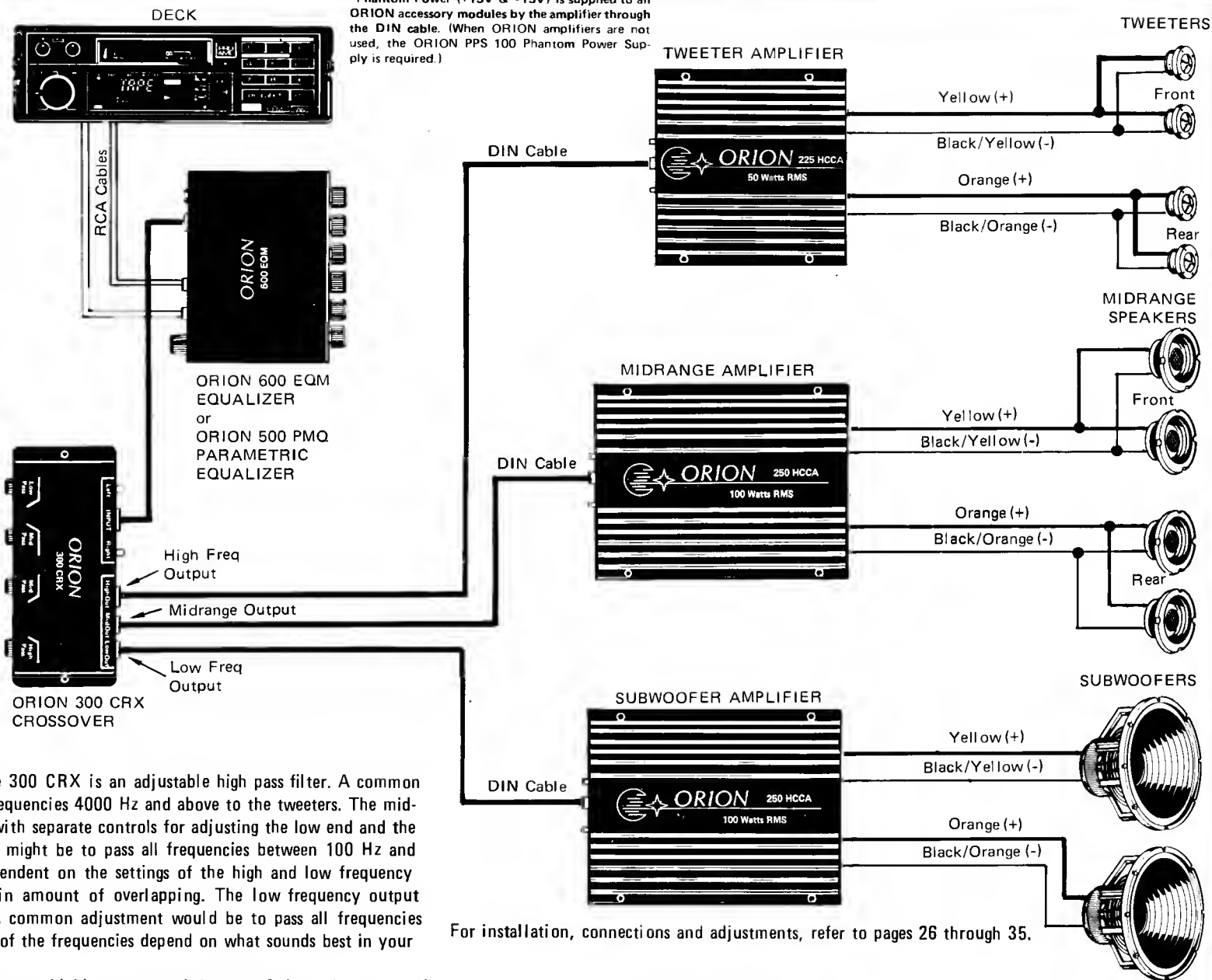

For installation, connections and adjustments, refer to pages 26 through 35.

Figure 7. Three-Amplifier System Using a 300 CRX 3-Way Active Crossover

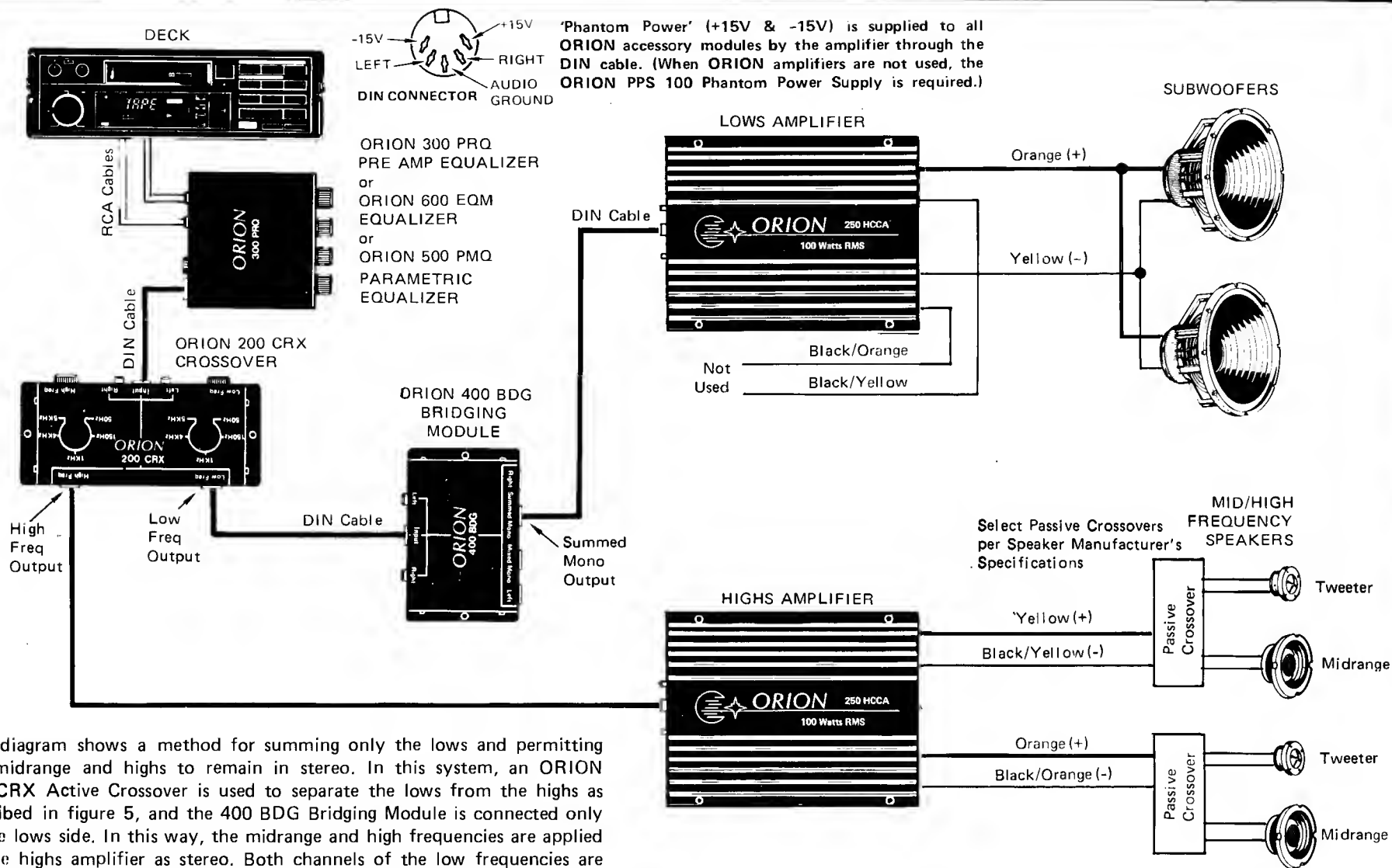

This diagram shows a method for summing only the lows and permitting the midrange and highs to remain in stereo. In this system, an ORION 200 CRX Active Crossover is used to separate the lows from the highs as described in figure 5, and the 400 BDG Bridging Module is connected only to the lows side. In this way, the midrange and high frequencies are applied to the highs amplifier as stereo. Both channels of the low frequencies are applied to the Bridging Module. In the 400 BDG Bridging Module, the signals for one channel are turned over 180 degrees (inverted) with respect to the other channel. The inverted channel output of the amplifier is now used as speaker ground and the non-inverted channel output is used as speaker positive. The BLACK/YELLOW and BLACK/ORANGE leads are NOT used.

This diagram shows two 8-ohm subwoofers connected in parallel. This reduces the impedance to a total of 4 ohms thus increasing the effective power output even more.

For installation, connections and adjustments, refer to pages 26 through 35.

Figure 8. Two-Amplifier System Using 200 CRX Active Crossover and the Summed Mono Output of a 400 BDG Bridging Module to Increase the Power Delivered to the Subwoofers by Four Times

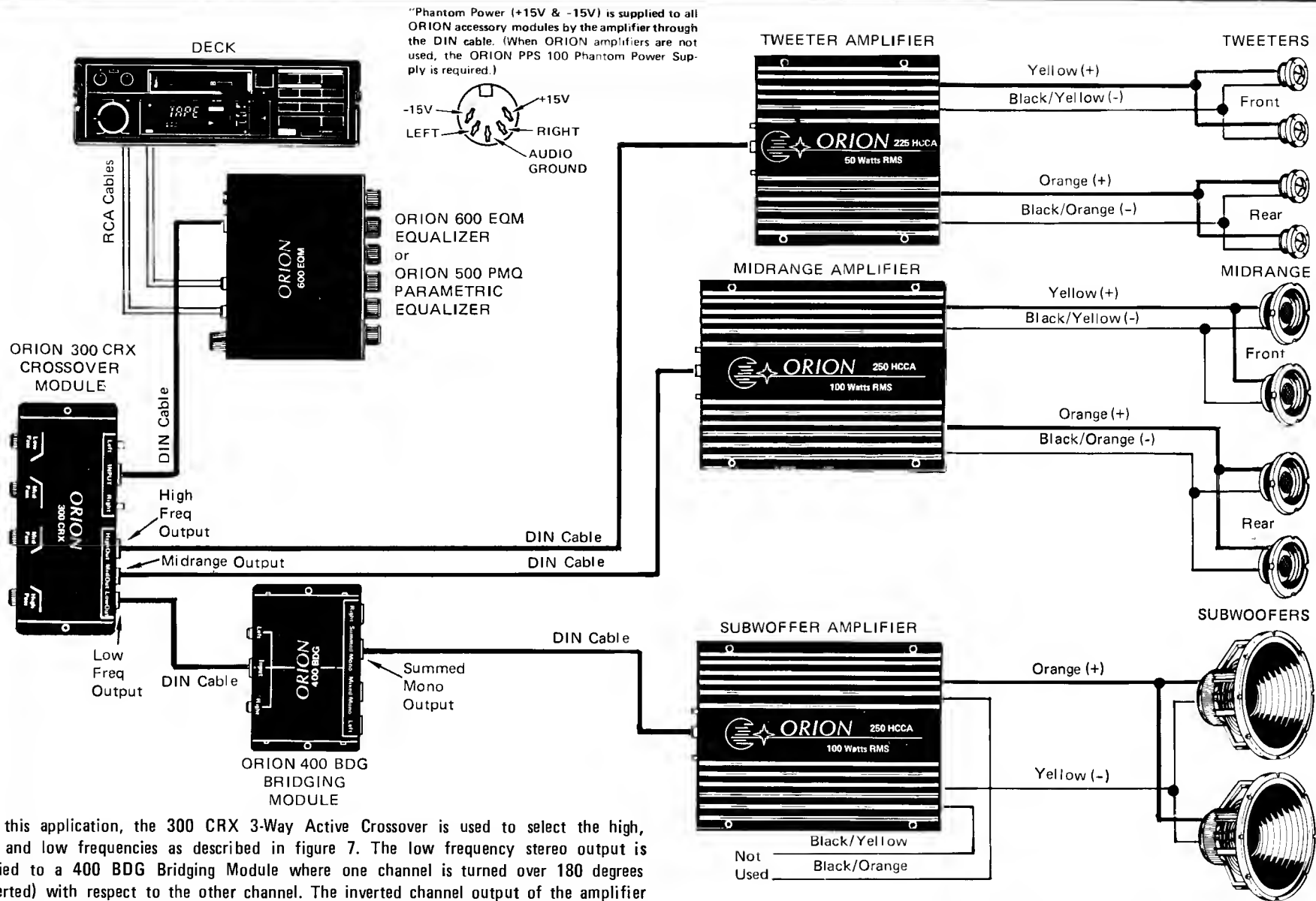

For this application, the 300 CRX 3-Way Active Crossover is used to select the high, mid and low frequencies as described in figure 7. The low frequency stereo output is applied to a 400 BDG Bridging Module where one channel is turned over 180 degrees (inverted) with respect to the other channel. The inverted channel output of the amplifier is now used as speaker ground and the non-inverted channel is used as speaker positive. The BLACK/YELLOW and BLACK/ORANGE leads are NOT used. Two 8-ohm subwoofers are connected in parallel. This reduces the impedance to 4 ohms, thus increasing the effective power even more.

A single amplifier is used to drive all tweeters, another amplifier is used to drive all mid-range speakers, in addition to the amplifier that drives the subwoofers. This makes for a very clean and efficient system since each speaker only has to handle those frequencies for which it was specifically designed.

Figure 9. Three-Amplifier System Using a 300 CRX 3-Way Active Crossover to Select High, Mid and Low Frequencies and a 400 BDG Bridging Module

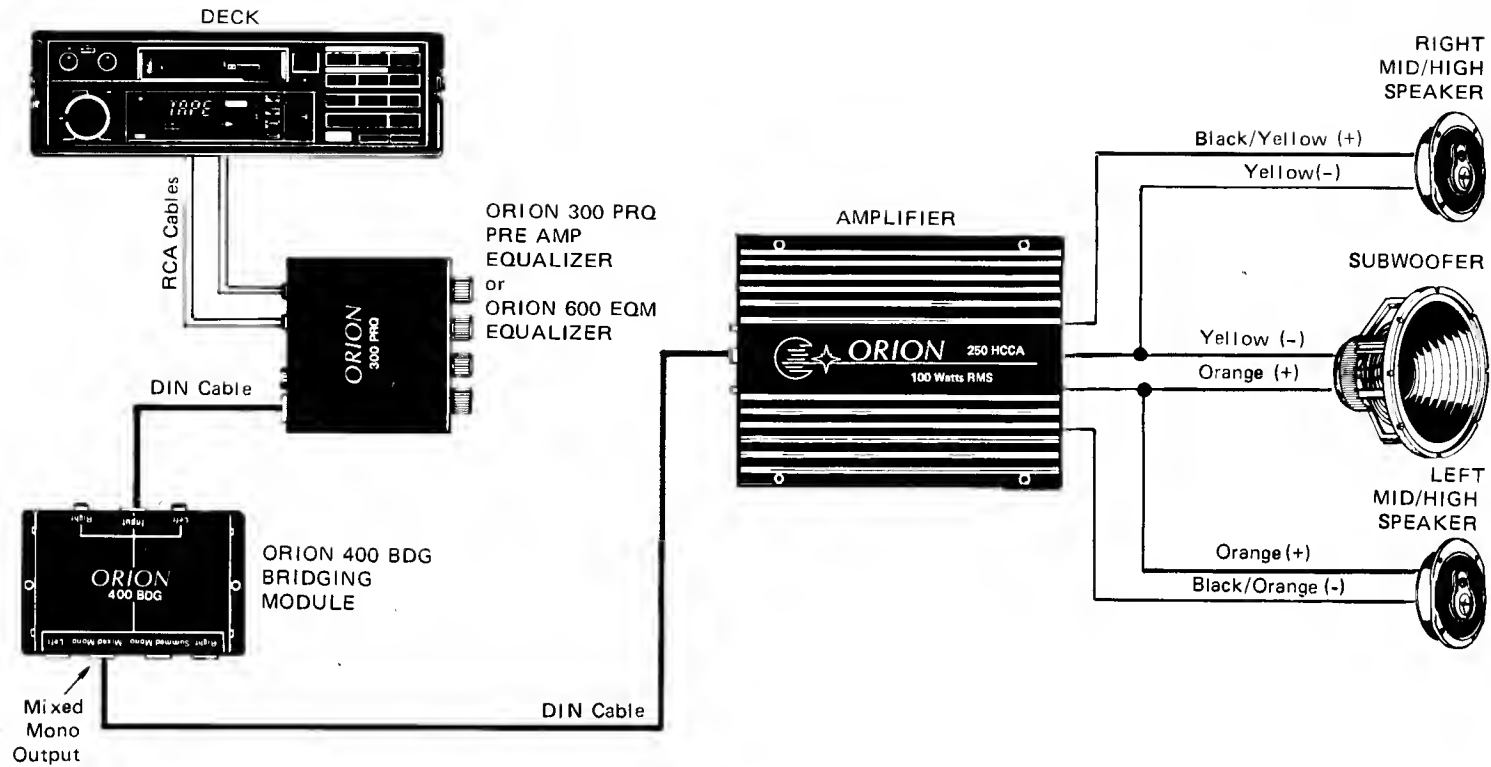

Mixed mono operation using a 400 BDG Bridging Module is the approach to use when you want to add a subwoofer to the a single amplifier system. This mode can be used to provide more power to the subwoofer while maintaining stereo left and right. In this system, the 400 BDG Bridging Module accepts the stereo inputs and turns one channel over 180 degrees (inverts the channel).

Both channel outputs of the amplifier are now connected to the subwoofer with the inverted channel being used as the negative input. This works because the two channels are 180 degrees out-of-phase.

The left mid/high speaker is connected normally, but the connections to the right mid/high speaker must be turned over to retain the stereo effect. This means that the yellow lead now becomes the negative lead and the black/yellow lead becomes the positive lead.

A REMINDER: *The speakers must never be grounded to the car chassis or body. To do so will cause severe noise problems and, in the case of bridging, cancel out the two-phase operation.*

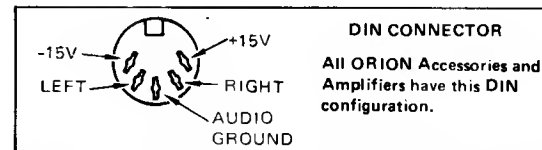

'Phantom Power' (+15V & -15V) is supplied to all ORION accessory modules by the amplifier through the DIN cable. (When ORION amplifiers are not used, the ORION PPS 100 Phantom Power Supply is required.)

Figure 10. Mixed Mono Connections in a Single Stereo Amplifier System Using a 400 BDG Bridging Module

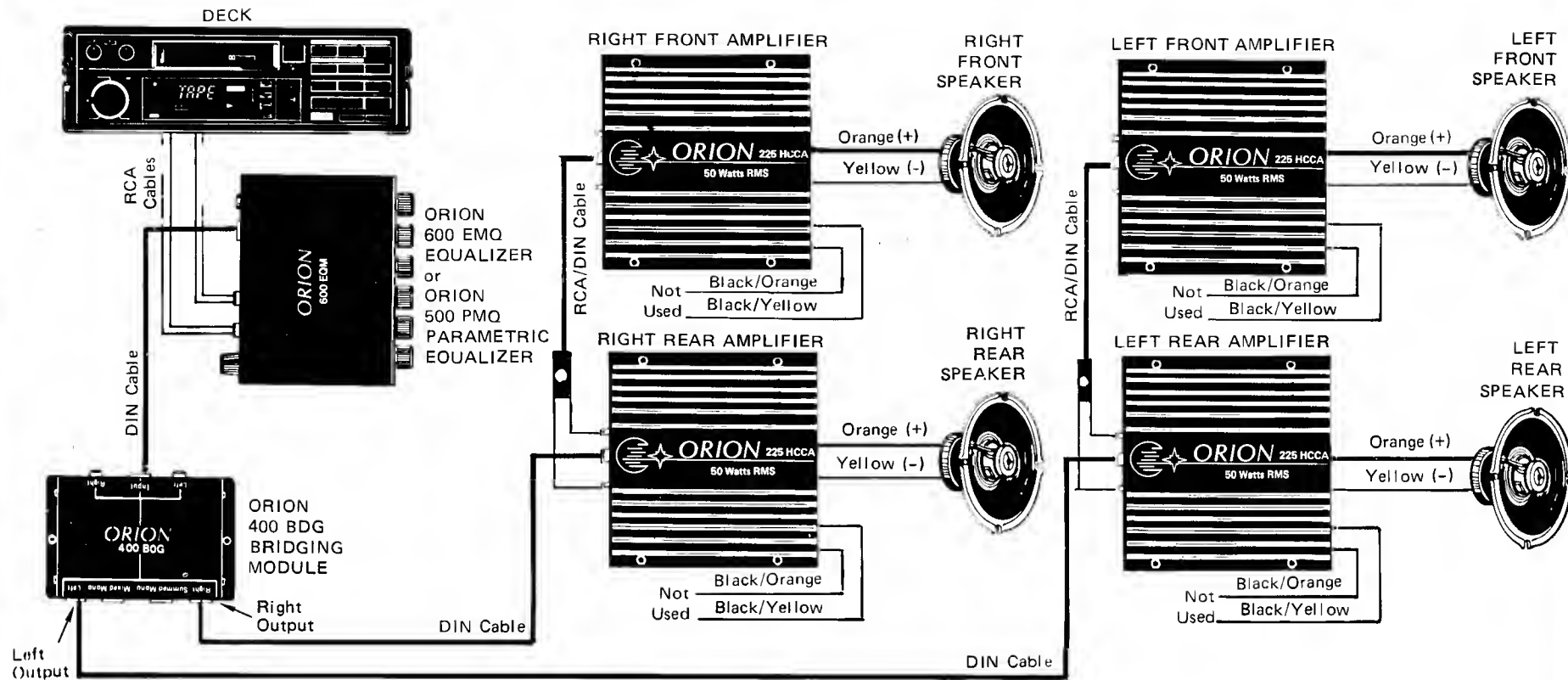

This application is used when you want to maintain the stereo effect while doubling the output power of your amplifiers. The right amplifiers are connected to the RIGHT output of the 400 BDG Bridging Module and the left amplifiers are connected to the LEFT output.

In this system, the 400 BDG Bridging Module accepts the stereo inputs and turns one channel over 180 degrees (inverts the channel). Both channel outputs of each amplifier are now connected to the speaker with the inverted channel being used as the negative input. This works because the two channels are 180 degrees out-of-phase.

The ORANGE lead from each amplifier is used as the positive lead and the YELLOW lead is used as the negative lead. The BLACK/YELLOW and BLACK/ORANGE leads are not used.

A REMINDER: The speakers must never be grounded to the car chassis or body. To do so will cause severe noise problems and, in the case of bridging, cancel out the two-phase operation.

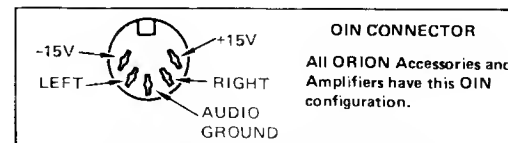

"Phantom Power (+15V & -15V) is supplied to all ORION accessory modules by the amplifier through the DIN cable. (When ORION amplifiers are not used, the ORION PPS 100 Phantom Power Supply is required.)

Figure 11. Method of Doubling Output of Amplifiers Using Bridged Stereo Right and Left

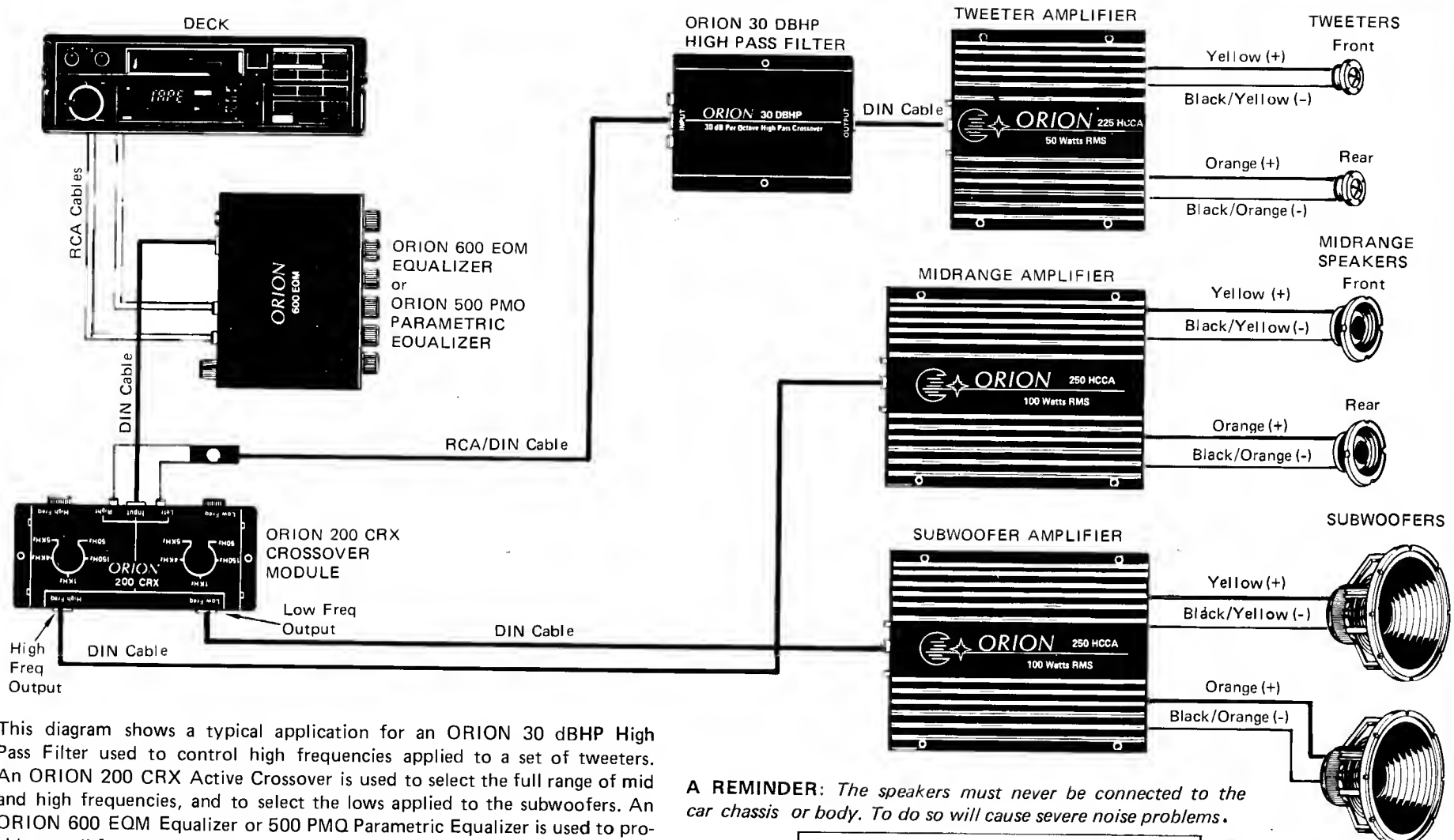

This diagram shows a typical application for an ORION 30 dBHP High Pass Filter used to control high frequencies applied to a set of tweeters. An ORION 200 CRX Active Crossover is used to select the full range of mid and high frequencies, and to select the lows applied to the subwoofers. An ORION 600 EQM Equalizer or 500 PMQ Parametric Equalizer is used to provide overall frequency control.

The RCA and DIN connectors at the INPUT to the 200 CRX Active Crossover are connected in parallel so that the RCA connectors can be used to connect the input stereo signals to the 30 dBHP High Pass Filter. Since the high pass filter input is received directly from the equalizer, the crossover module has not affect on the high pass filter.

A REMINDER: *The speakers must never be connected to the car chassis or body. To do so will cause severe noise problems.*

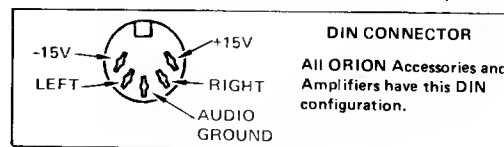

"Phantom Power (+15V & -15V) is supplied to all ORION accessory modules by the amplifier through the DIN cable. (When ORION amplifiers are not used, the ORION PPS 100 Phantom Power Supply is required.)

Figure 13. Typical Use of an ORION 30 dBHP High Pass Filter to Set Lower Limits of High Frequencies

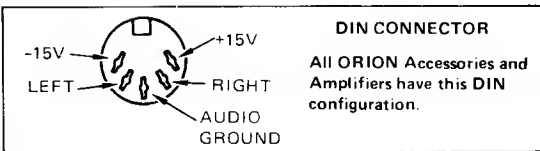
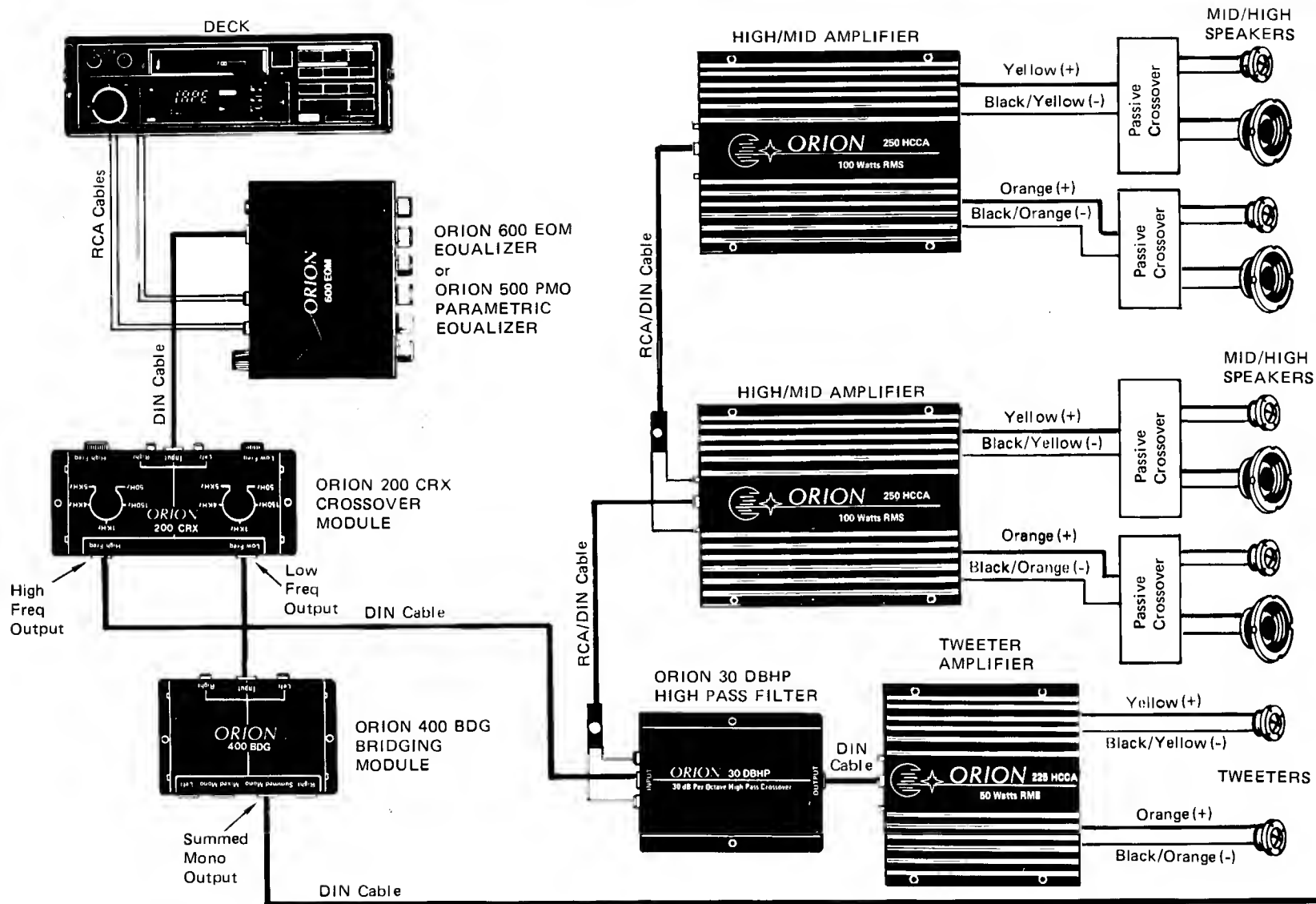

'Phantom Power' (+15V & -15V) is supplied to all ORION accessory modules by the amplifier through the DIN cable. (When ORION amplifiers are not used, the ORION PPS 100 Phantom Power Supply is required.)

Figure 14. "Killer System" Using ORION Low Pass and High Pass Filters to Fine Tune the System

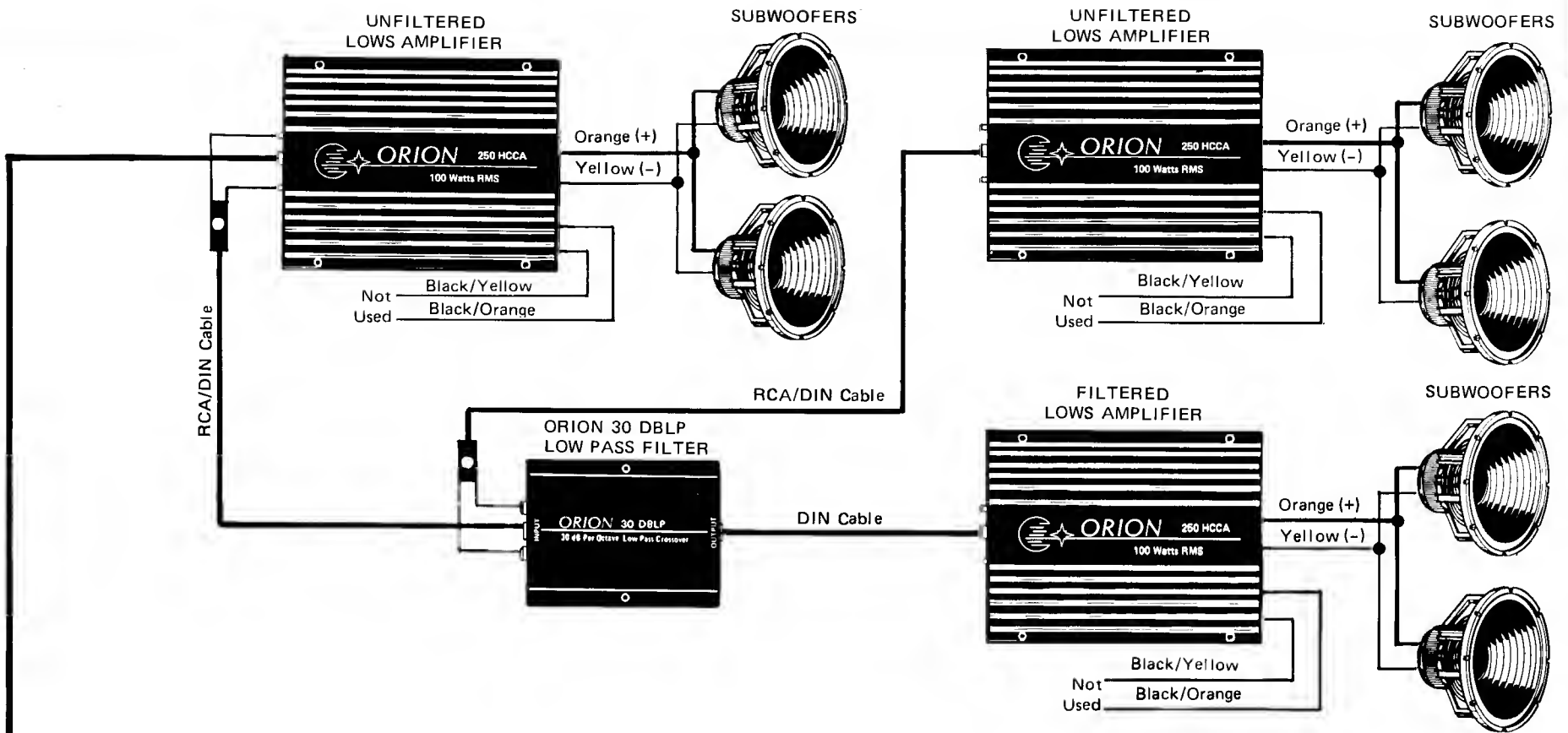

This diagram shows a full competition "Killer System" that has been fine tuned using ORION Low Pass and High Pass Filters. An ORION 200 CRX Active Crossover is used to separate the high/mids from the lows. The lows are then applied to a 400 BDG Bridging Module. The SUMMED MONO output is supplied to two lows amplifiers that amplify the full spectrum of lows selected at the 200 CRX (say 260 Hz and below). Each low amplifier then drives two subwoofers. Up to 20 amplifiers could be connected in parallel as shown here.

The lows output of the 200 CRX Active Crossover is also applied to an ORION 30 dBLP Low Pass Filter that selects a cutoff frequency that will emphasize only the lower range (say 72 Hz and below).

The high frequency output of the 200 CRX Active Crossover is applied to two high/midrange amplifiers which reproduce the full spectrum of selected high and mid frequencies (say 200 to 4200 Hz).

The high frequency output is also applied to an ORION 30 dBHP High Pass Filter that selects a cutoff frequency that will emphasize only the highest frequencies (say 4000 Hz and above).

An ORION 600 EQM Equalizer or 500 PMQ Parametric Equalizer is used to balance the overall system.

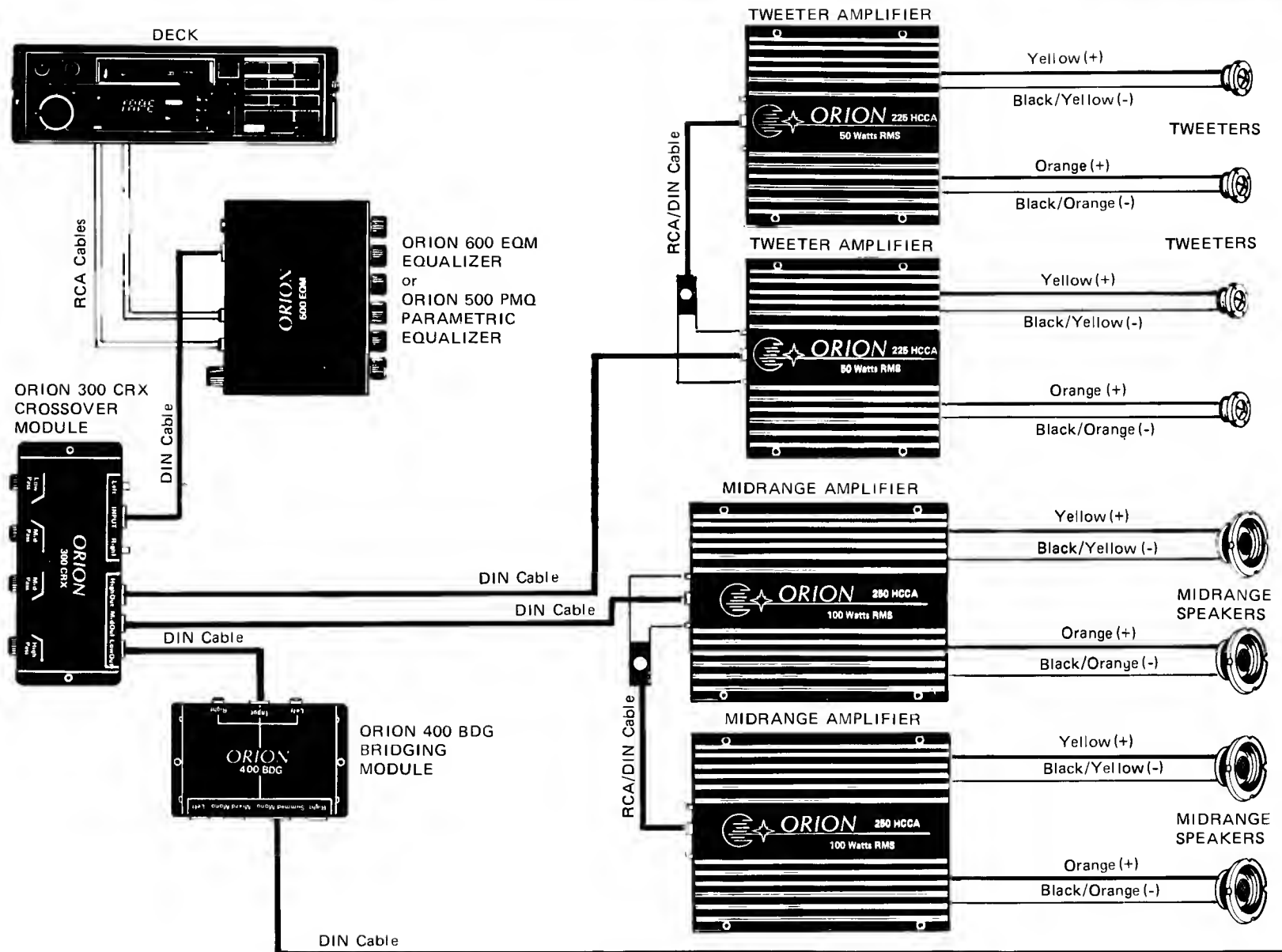
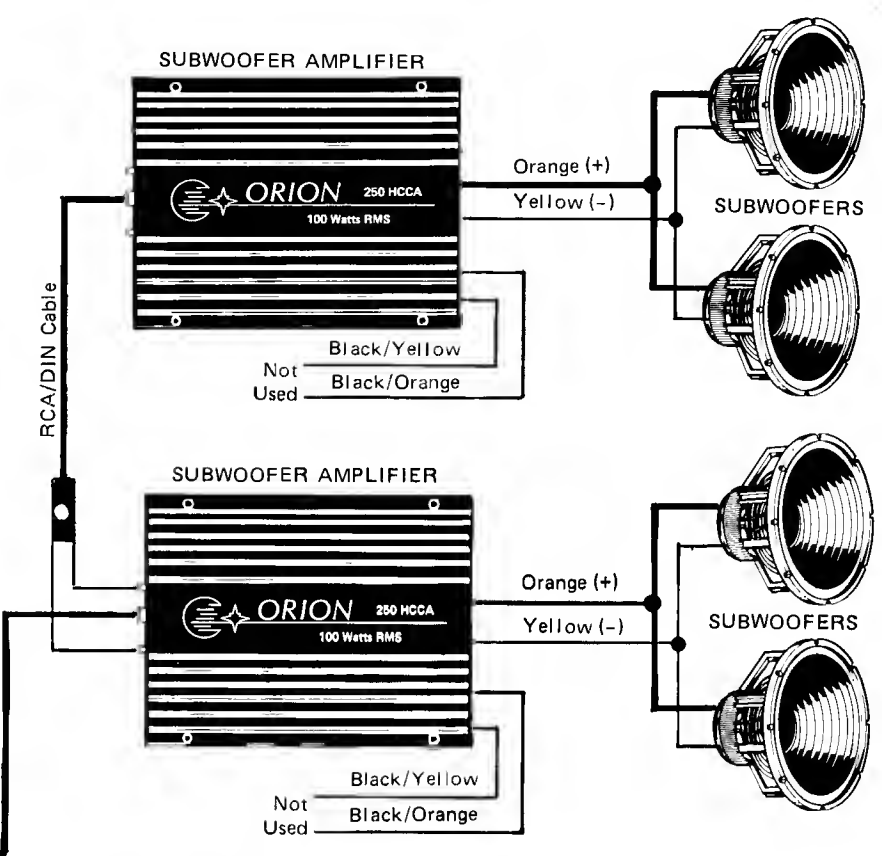
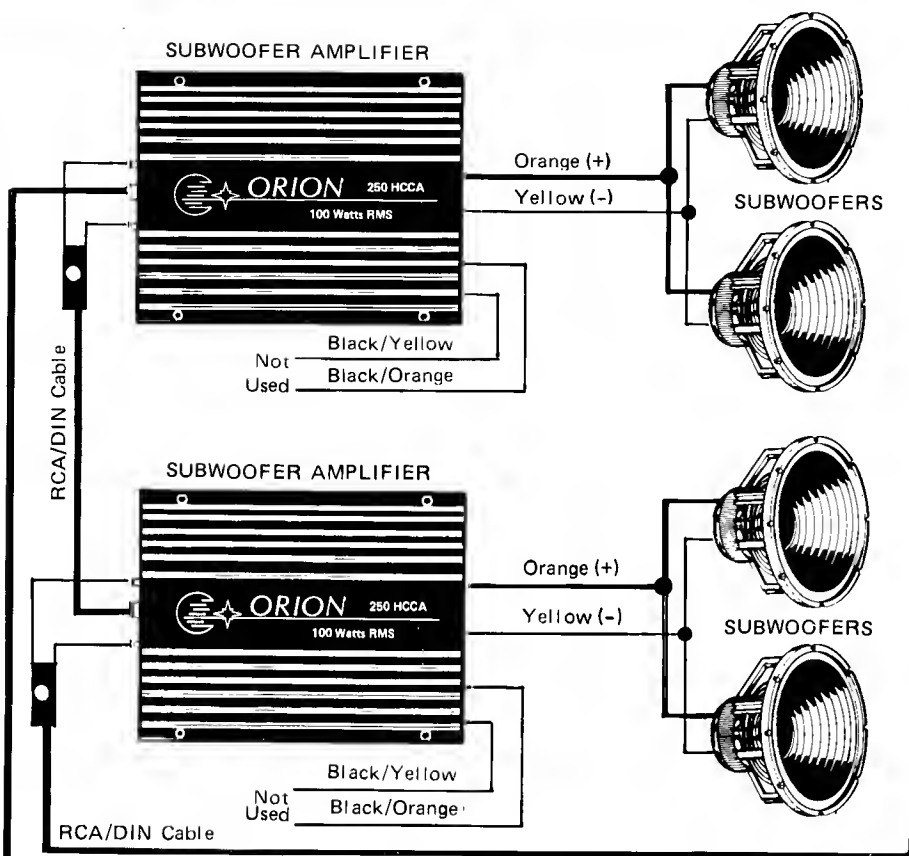

Figure 15. "Killer System" Utilizing a 300 CRX 3-Way Active Crossover and Individual Amplifiers for Each Speaker Type
 (Up to 20 Subwoofer Amplifiers Can be Used)



This diagram shows a full competition "Killer System" using an ORION 300 CRX 3-Way Active Crossover to separate the highs, midranges and lows. This allows each type of speaker to handle only those frequencies it was designed to reproduce. The lows are then applied to an ORION 400 BDG Bridging Module. The Summed Mono output can now be used to drive up to 20 amplifiers connected in parallel as shown in the diagram.

The selected high frequencies are kept in stereo and applied to a pair of tweeter amplifiers. Since the high frequencies require much less power, the diagrams shows smaller amplifiers for driving the tweeters than those used for the mid and low frequencies.

The selected midrange frequencies are also kept in stereo and applied to a pair of amplifiers that drive the midrange speakers.

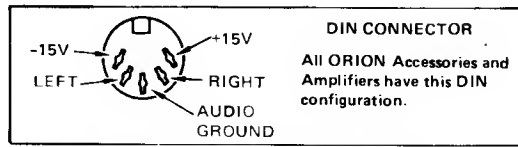

"Phantom Power (+15V & -15V) is supplied to all ORION accessory modules by the amplifier through the DIN cable. (When ORION amplifiers are not used, the ORION PPS 100 Phantom Power Supply is required.)"

This figure shows the use of a 425 HCCA 4-Channel Amplifier in a car equipped with front and rear full range speakers.

The 425 HCCA does not have input RCA connectors connected in parallel with the input DIN connector, as used in the other HCCA amplifiers. An ORION 300 PRQ Dual-Amp Balancer is installed in the system to provide the connections for separating front and rear and to provide a means for front and rear level adjust.

Figure 17 on the next page shows a typical method of using two 425 HCCA 4-Channel Amplifiers as an efficient multi-amplifier system. In this system, each pair of tweeters and midrange speakers are driven by a separate stereo amplifier within the 425 HCCA. An ORION 300 CRX Crossover Module is used to select the frequency ranges applied at the input to the amplifiers.

Each pair of subwoofer amplifiers is bridged to provide 200 watts of power to a pair of 4-ohm subwoofers connected in parallel. An ORION 200 DAB Dual-Amp Balancer is used to fine tune the level delivered to each pair of subwoofers.

In the right vehicle, this system would be an impressive competition system. The metallic red color of the amplifiers would provide visual impact and the audio performance and sonic quality would be very impressive.

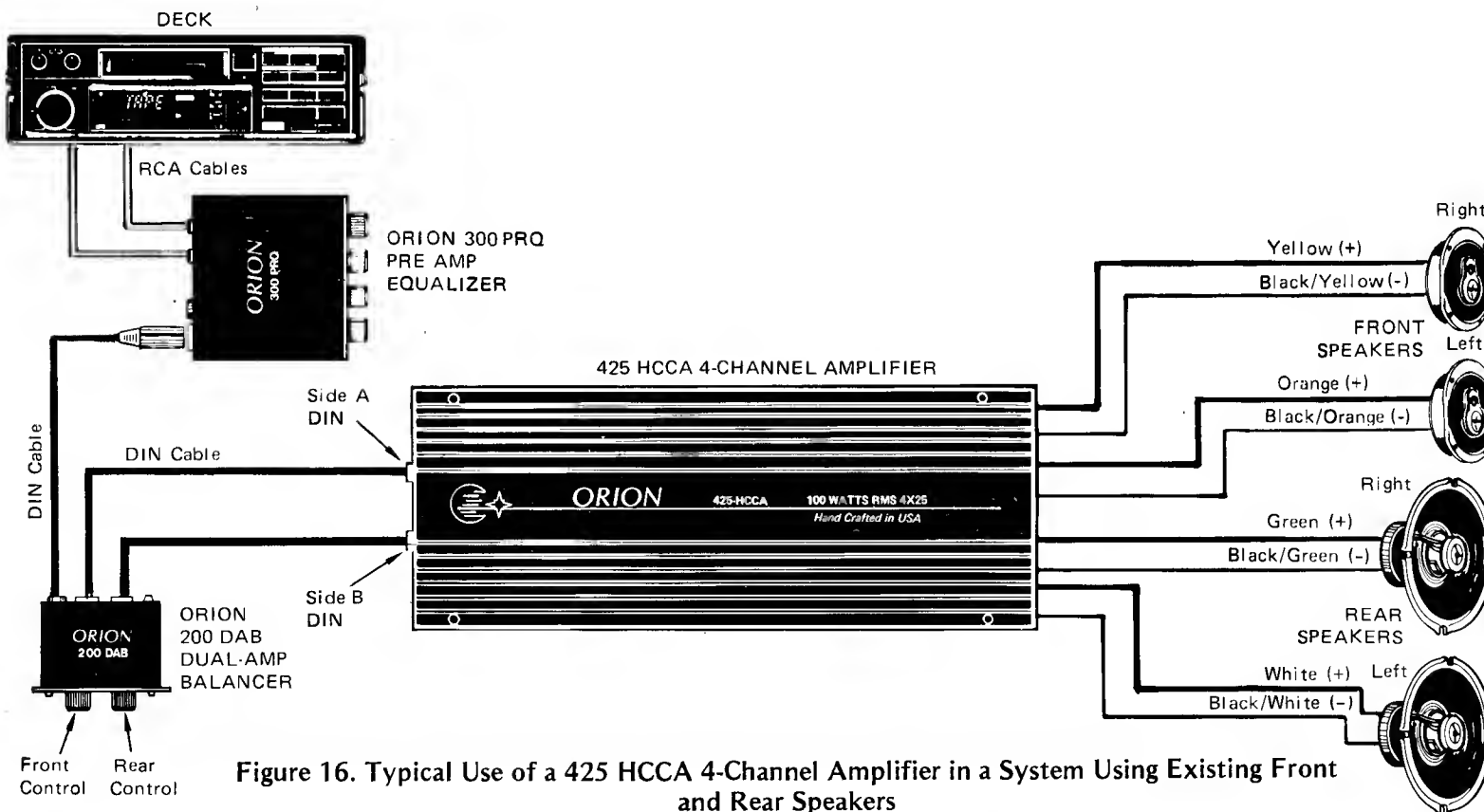

Figure 16. Typical Use of a 425 HCCA 4-Channel Amplifier in a System Using Existing Front and Rear Speakers

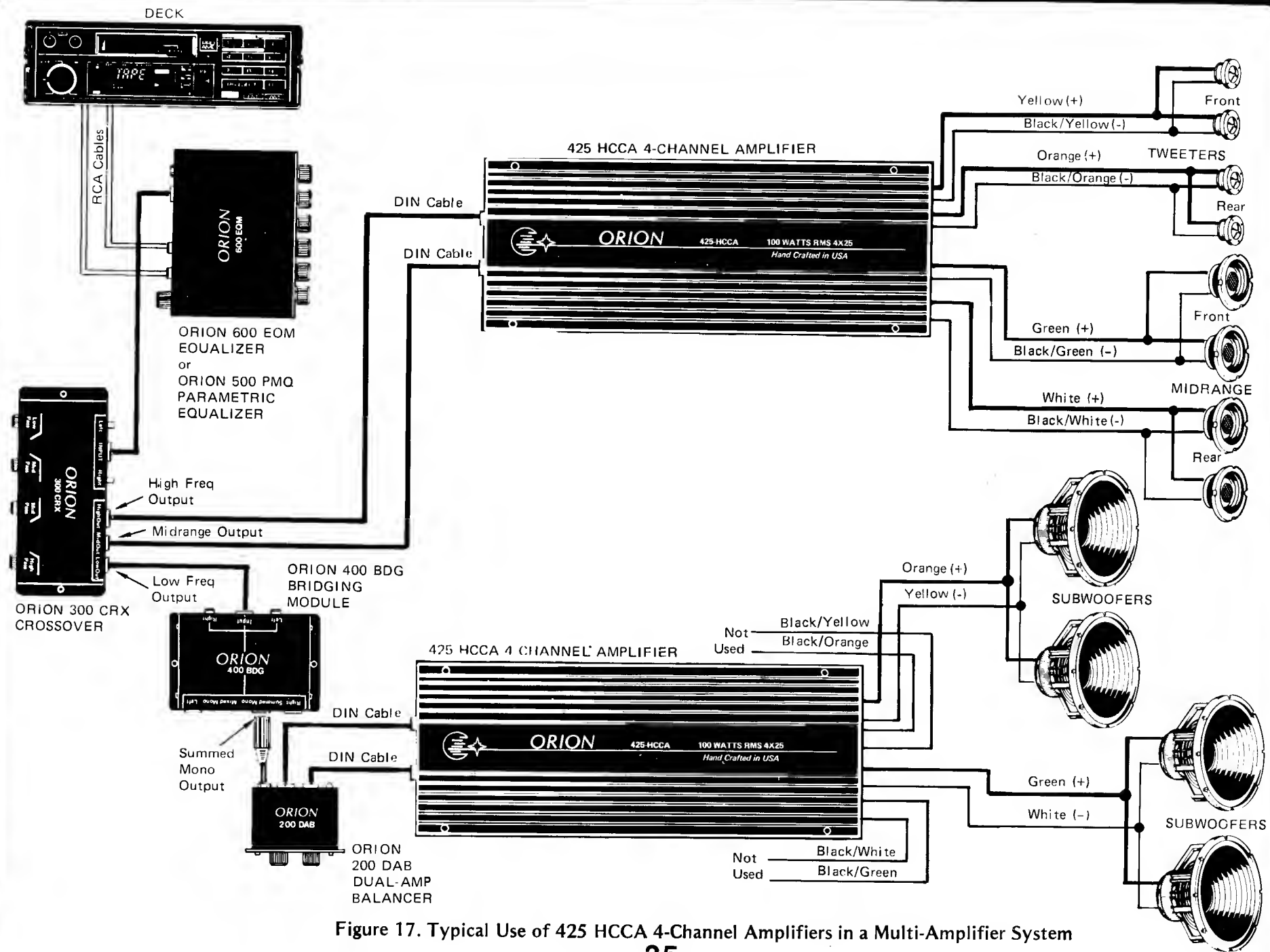

Figure 17. Typical Use of 425 HCCA 4-Channel Amplifiers in a Multi-Amplifier System

MOUNTING THE AMPLIFIER

When planning where to install your amplifier, you must first think in terms of keeping the amplifier cool enough to function properly. Amplifiers are heat-sensitive. This means that the operating parameters may change with fluctuations in temperature and an amplifier can literally be destroyed by excessive heat during operation.

The finned outer surface of the amplifier is a *heat sink* which helps to carry heat away by means of thermal conduction. Therefore, you must allow the amplifier to breathe so that the heat sink can best do its job.

It is always best to mount the amplifier flat on the floor under the front seat on in the front of the car trunk. Remember heat travels up.

- Avoid heat traps.

- Don't put a glass or metal cover over the top of the amplifier unless you have a cooling fan at one end.
- Keep in mind that any moving air dissipates heat.
- If possible, duct the car air conditioning system so that cooling air is directed along the fins of the amplifier heat sink.
- Cooling air should be directed along the fins rather than across them for the most efficient cooling.

- Don't mount the amplifier on plastic or use a plastic cover. The plastic will melt.

Once you have selected the mounting location, mount the amplifier using the four self-tapping screws provided. Tighten the screws securely.

CAUTION

Be very careful not to drill into the fuel tank, fuel lines, or through electrical wiring.

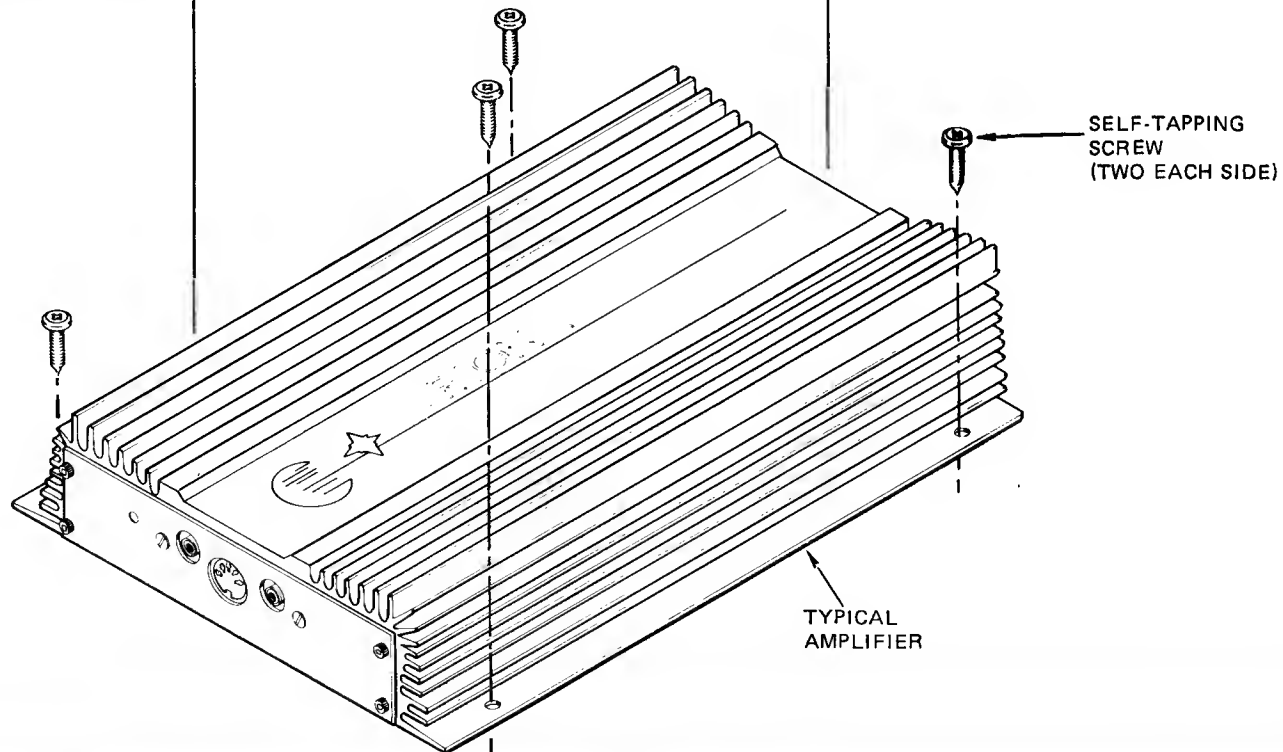

POWER AND GROUND CONNECTIONS

IMPORTANT CAUTIONS

1. Improper wiring connections can seriously damage amplifiers, accessories, or speakers. Follow the connecting instructions in this manual carefully. When in doubt, contact your dealer.
2. Disconnect the battery positive (+) lead before making any power connections.
3. Always connect the power cable assembly directly to the positive (+) terminal on the battery. Do NOT connect to the car fuse panel. Do NOT use a smaller gage wire for the hot lead than that coming out of your amplifier.
4. Make sure that the power ON-OFF switch that controls the amplifiers is turned OFF when making any connections.
5. Make sure that all connections are clean and properly secured. Failure to do so may result in damage to your equipment.
6. Always replace fuses with the same FAST BLOW current rating as those supplied with your amplifier. Incorrect fuses can result in serious damage to the components in the system.
7. The speakers must never be grounded to the car chassis or body. To do so will cause severe noise problems and, in case of bridging, cancel out the two-phase operation.
8. Make sure that your car has enough power to handle all car systems as well as your audio system. Read about power requirements below carefully.

A. Low Power Systems

Before installing your audio system, you must make sure that your car has enough 12-volt power to service all of the car electrical components (engine, headlights, windshield wipers, air conditioning, etc.) and still handle the power required to supply your audio system at full power.

Use a little common sense. If you are installing a system containing two or three 225 HCCA or a single 250 HCCA amplifier, your existing factory electrical system will probably handle your power requirements.

An existing system will handle a 250 HCCA or 425 HCCA amplifier just fine, but if you install two of these amplifiers, you probably won't be able to run the system at full power at night with the headlights on. If you want to install two of these amplifiers and run at full power at night, you will probably have to install a heavy duty alternator and a premium (or even a second battery as described in B below.

If you attempt to overload your existing system, you will burn out the brushes or field diodes in your alternator and greatly reduce the life of your battery.

B. Multiple Amplifier Systems

Multiple-amplifier systems (except as described in A above) require additional battery and/or charging power.

Competition systems, such as those shown in figures 14, 15, and 17, should contain multiple batteries or be powered by an external battery charger or dc power supply with a current rating in excess of that required by all combinations of the components in your system.

For standard multi-amplifier systems, you must install a heavy duty alternator and at least one extra battery. Preferably, all batteries should be deep cycle marine batteries.

When batteries are connected in parallel, the voltage across each battery is the same and the batteries share the load current. The alternator will generally maintain the charge on both batteries equally.

The power lead for each amplifier should be connected directly to the positive terminal as shown on page 32. In large multi-amplifier systems, the power leads can be connected to a heavy buss bar, but the lead from the buss bar to the battery positive terminal must be at least No. 4 wire gage for 100 ampere service.

Keep in mind that an amplifier can only supply its full power if it has enough battery power being supplied to it.

All ORION amplifiers are designed to mute 40 dB if battery power drops below 10 volts.

C. Grounding Amplifiers

For any audio system, you should first go to the battery and get rid of that little 12 or 14 gage wire that goes from the ground terminal to the chassis and install a braided ground strap at least 1-inch wide from the battery negative terminal to the chassis. Leave the original ground strap connected to the engine.

The ground wire for each amplifier must be connected directly to the car chassis not more than 18 inches from the amplifier. Longer ground leads will usually cause ground loops.

Do NOT ground the amplifiers at the same point. Use a separate grounding point for each amplifier.

The ground point should be a metal chassis member that is welded to the main body of the car. Scrape any paint from the grounding point and clean with sandpaper just before attaching the ground lug. After the ground lug has been securely tightened, cover the bare metal area with paint or grease to prevent rust.

The ground lead is every bit as important as the power lead. Many audio systems troubles are the result of improper ground connections.

Ground is a term generally used to describe the common connection in an electrical or electronic circuit. The common connection is usually the same potential for all circuits in the system. It is the source of electron flow. Remember that the basic principle is that electrons flow from negative to positive.

In cars, the ground is almost always the metal chassis or body and originates at the negative (-) terminal of the battery.

A ground connection should have the least possible resistance which is why we emphasize that the ground wire for an amplifier should be as short as possible (18-inches long maximum). Longer wires add resistance and make the circuit susceptible to ground loops which can result in hum pickup and other electromagnetic interference.

Electromagnetic interference is a combination of electric and magnetic fields caused by alternating current (or frequencies) radiating from the wires and being picked up on the signal leads to and from your amplifier. This type interference may show up as popping, bursts of static, or random noise.

Floating Ground

Floating ground means that the ground is not connected to the car chassis or body, but uses only the internal power supply ground. Some radios and cassette decks use a floating ground for the output signals. This is a dedicated ground connection that remains isolated from the common circuit ground (car chassis or body).

Some ORION amplifiers contain a small diameter black lead in addition to the larger common ground wire. This lead is for connections to the floating ground for those decks that use a floating ground.

To determine if the floating ground connection should be made, first connect the system **WITHOUT** connecting the floating ground. Start the car and turn on the audio system. Temporarily connect the floating ground. If the floating ground adds noise, do **NOT** connect. If the floating ground takes away noise, connect the floating ground permanently.

If the deck utilizes a floating ground and the small black wire is not connected to the deck floating ground point, any of the following conditions may result:

- Clipped output
- Blown fuses
- Weak output from the amplifier
- Amplifier will run hot
- Squealing

Phantom Power

Phantom Power (+15V and -15V) is present at all DIN connectors at the **INPUT** to all ORION amplifiers. This voltage is for use in providing operating power to any ORION accessory that contains active electronic circuits. This includes all crossover modules, bridging modules, equalizers, and low pass and high pass filters.

NOTE: Active electronic circuits require a source of dc power for operation, offer no resistance to the signals, and often add gain. Passive electronic circuits, such as used for speaker crossovers, do not require dc power and add resistance to signals.

The ORION accessories use insignificant amounts of power and need not be figured into the overall power requirements for you audio system.

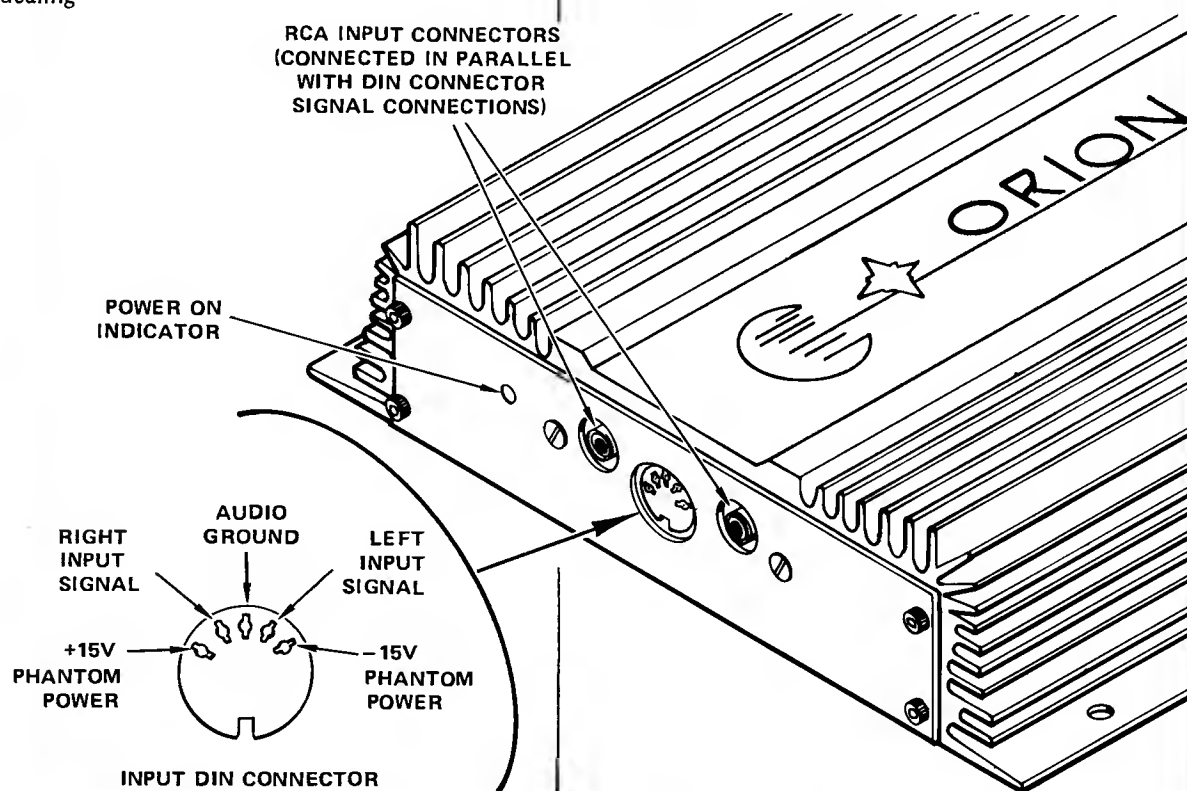

Power Connections for 225 HCCA

BATTERY CONNECTIONS. Always connect the power cable assembly directly to the positive terminal on the battery. *Do NOT connect to the car fuse panel.* The 225 HCCA is provided with two fuses. The fuse at the battery is designed to prevent fire or damage to your car should there be a ground short. The second fuse protects the amplifier itself. *Do NOT substitute fuses.* Always replace with fuses of the same fast blow current rating as those supplied with your amplifier.

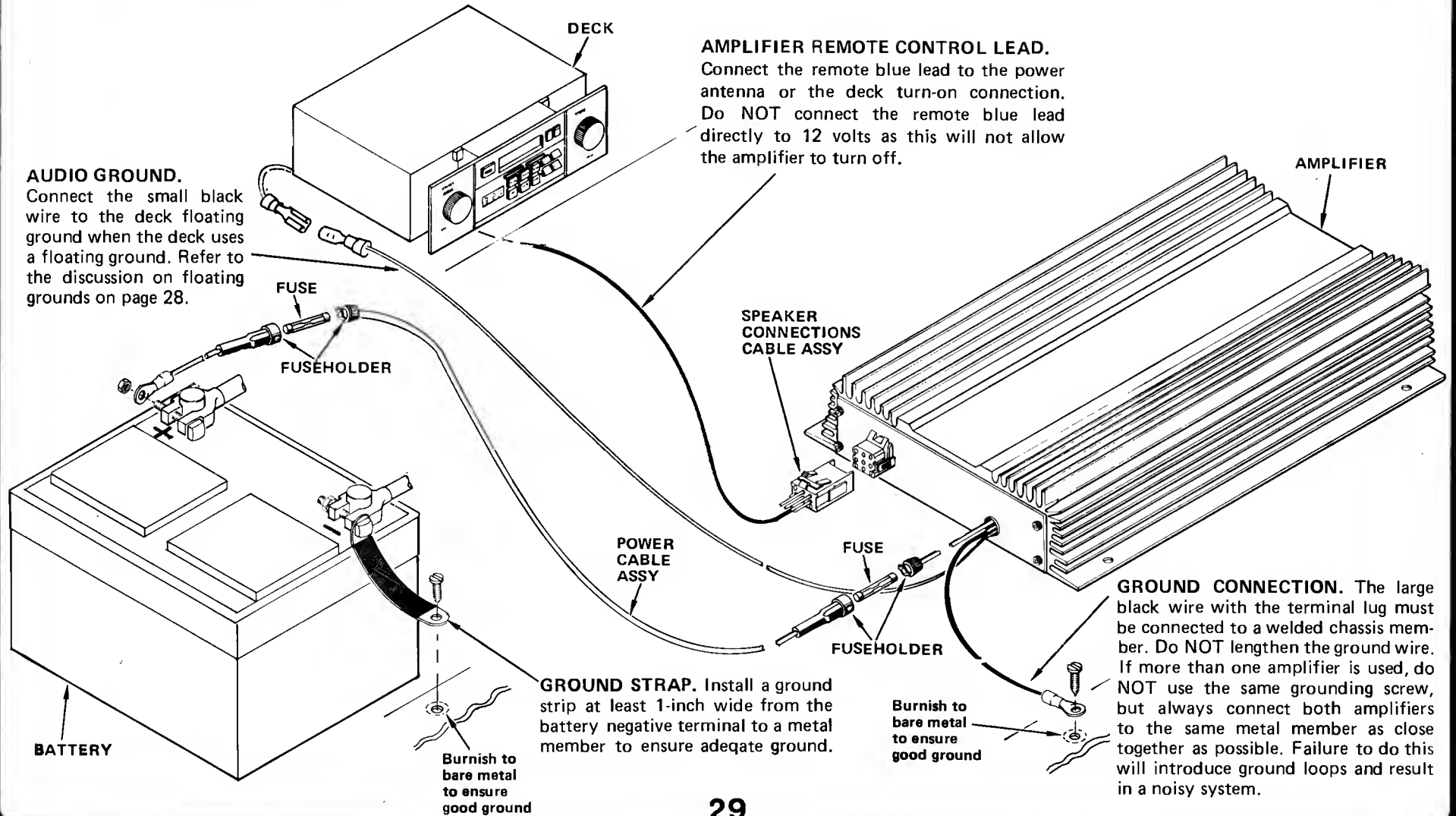

Power Connections for 250 HCCA

BATTERY CONNECTIONS. For most cars, the existing battery and charging system will handle a single 250 HCCA amplifier. If two or more amplifiers are to be used (or if the headlights dim when the amplifier is cranked up to full power), use two batteries connected in parallel as shown in this diagram. (Refer to the discussion on page 27.) A heavy duty fuseholder and fast blow 40 ampere fuse is provided with the amplifier. Install the fuseholder at the battery positive terminal. Always connect the power cable assembly directly to the battery. *Do NOT connect to the car fuse panel.* If the batteries are not installed side-by-side as shown here, install a heavy duty fuse in the hot lead between the two batteries. Also, install a ground strap for the second battery. Always replace the fuse with the same fast blow current rating as the one supplied with the amplifier.

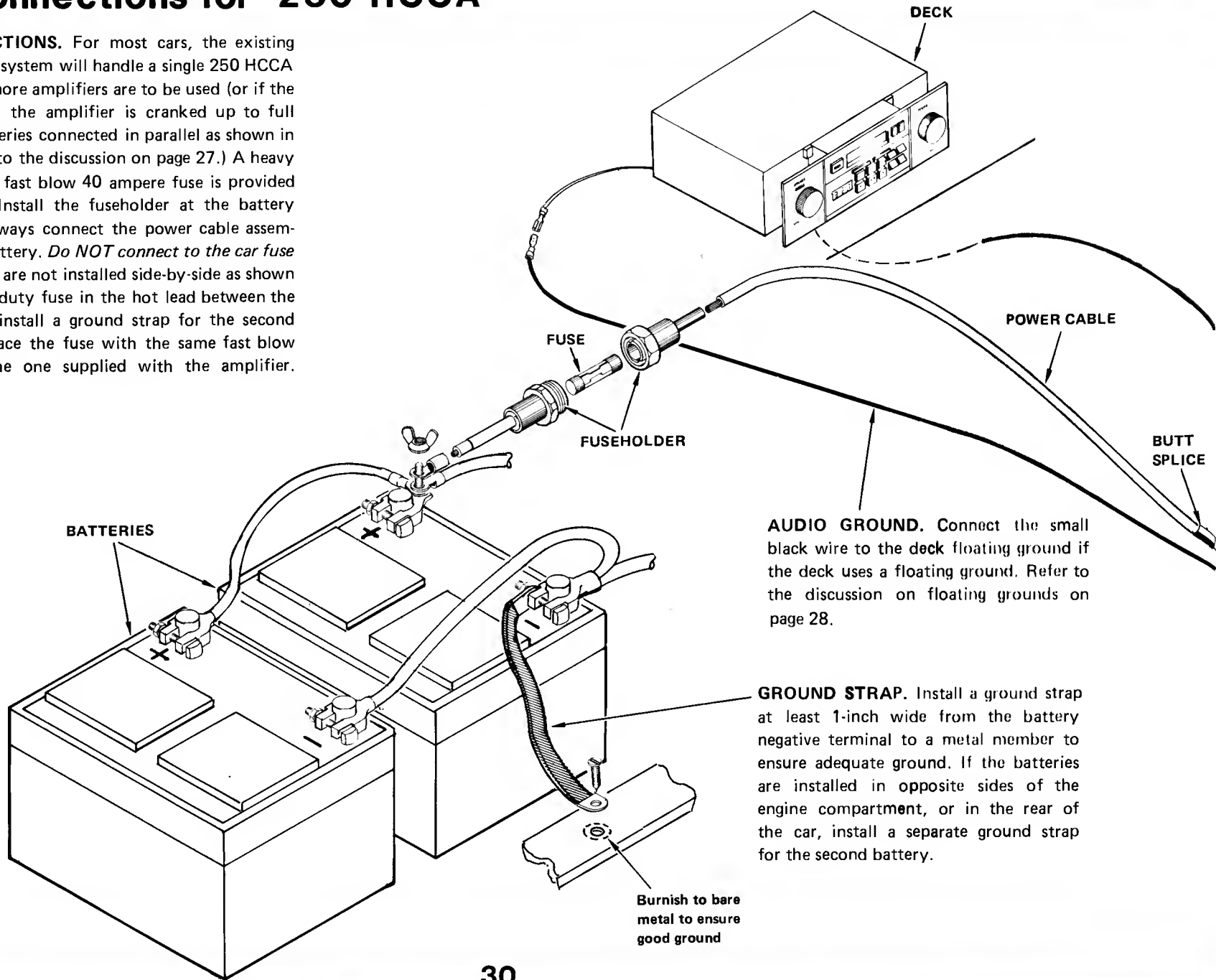

AUDIO GROUND. Connect the small black wire to the deck floating ground if the deck uses a floating ground. Refer to the discussion on floating grounds on page 28.

GROUND STRAP. Install a ground strap at least 1-inch wide from the battery negative terminal to a metal member to ensure adequate ground. If the batteries are installed in opposite sides of the engine compartment, or in the rear of the car, install a separate ground strap for the second battery.

Burnish to bare metal to ensure good ground

AMPLIFIER REMOTE CONTROL LEAD.

Connect the remote blue lead to the power antenna or the deck turn-on connection. Do NOT connect the remote blue lead directly to 12 volts as this will not allow the amplifier to turn off.

**BLUE REMOTE
TURN-ON/OFF
WIRE**

**SPEAKER
CONNECTIONS
CABLE ASSY**

AMPLIFIER

GROUND CONNECTION. The large black wire must be connected to a welded chassis member. Do NOT lengthen the ground wire. If more than one amplifier is used, do NOT use the same ground screw, but always connect both amplifiers to the same metal member as close together as possible. Failure to do this will introduce ground loops and result in a noisy system.

**Burnish to bare
metal to ensure
good ground**

Power Connections for 425 HCCA

BATTERY CONNECTIONS. For most cars, the existing battery and charging system will handle a single 425 HCCA 4-channel amplifier. If two or more amplifiers are to be used (or if the headlights dim when the amplifier is cranked up to full power), use two batteries connected in parallel as shown in this diagram. (Refer to the discussion on page 27.) The 425 HCCA is provided with four fuses. The fuse for each power cable assembly is designed to prevent fire or damage to your car should there be a ground short in the power cable. The second set of fuses protect each pair of amplifiers. *Do NOT substitute fuses. Always replace fuses with the same fast blow current rating as those supplied with your amplifier.*

Always connect the power cable assemblies directly to the positive terminal on the battery. *Do not connect to the fuse panel.* If the batteries are not installed side-by-side as shown here, install a heavy duty fuse in the hot lead between the two batteries. Also, install a ground strap for the second battery.

AUDIO GROUND. Connect the small black wire to the deck floating ground if the deck uses a floating ground. Refer to the discussion on floating grounds on page 28.

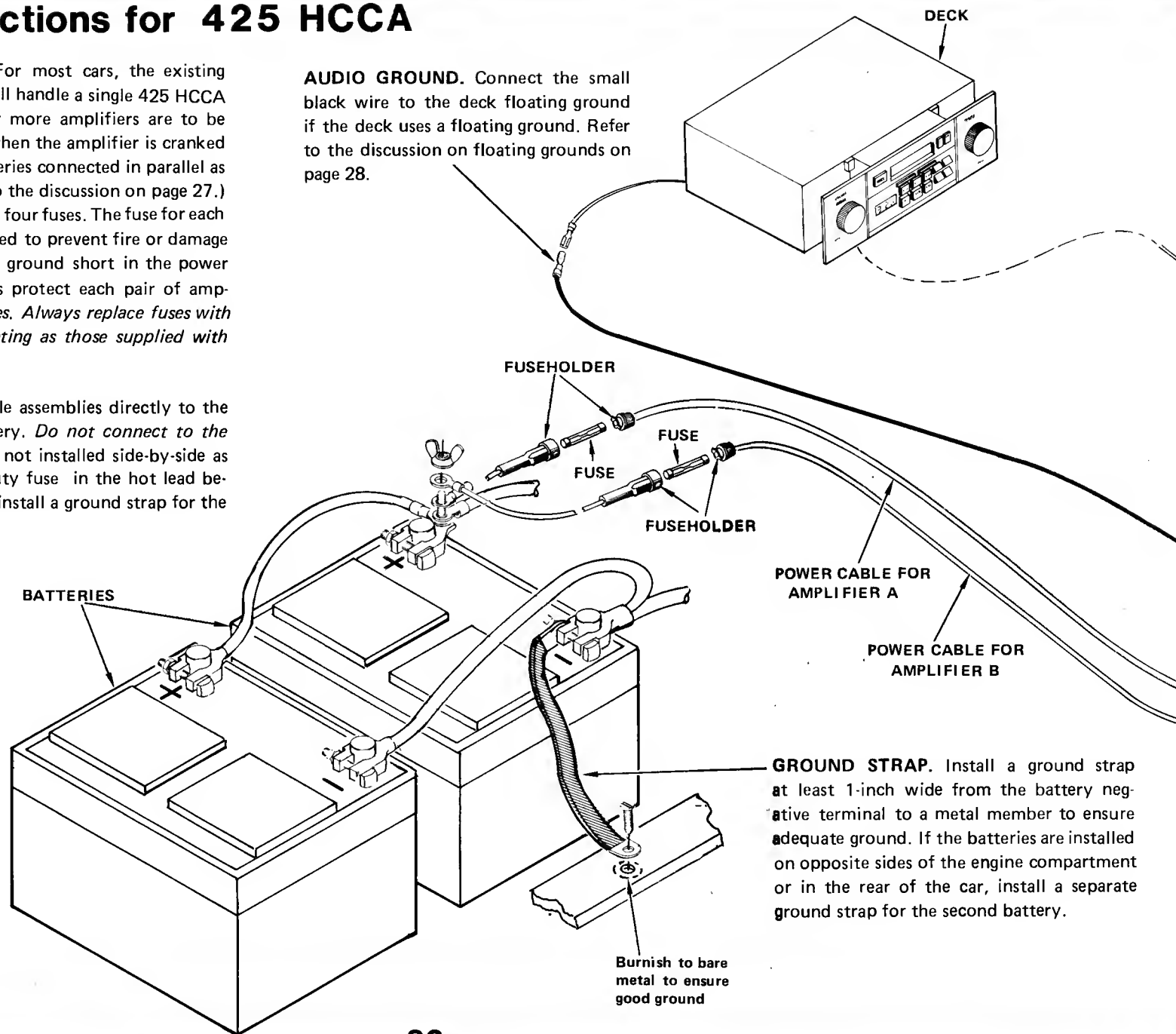

AMPLIFIER REMOTE CONTROL LEAD.

Connect the remote blue lead to the power antenna or the deck turn-on connection. Do NOT connect the remote blue lead directly to 12 volts as this will not allow the amplifier to turn off.

**BLUE REMOTE
TURN ON/OFF
WIRE**

**SPEAKER
CONNECTIONS
CABLE ASSY**

FUSE

FUSE

FUSEHOLDER

FUSEHOLDER

AMPLIFIER

**Burnish to bare
metal to ensure
good ground**

GROUND CONNECTION. The large black wires must be connected to a welded chassis member. Do NOT lengthen the ground wires. Connect the ground leads to the same metal member as close together as possible. Do NOT use the same ground screw for both ground leads.

SPEAKER CONNECTIONS

IMPEDANCE

225 and 425 HCCA amplifiers are designed for operation with 0.5 to 16 ohm speakers. 250 HCCA amplifiers are designed for operation with 1 to 16 ohm speakers. For best operation, we recommend high quality 8-ohm speakers. The efficiency of 8-ohm speakers tends to be a little better than 4-ohm speakers. You only get 3 dB gain from the increase in power by going from 8 ohms to 4 ohms. Many high quality 8-ohm subwoofers are actually 5 to 6 dB more efficient than 4-ohm subwoofers. Also, if you use 8-ohm speakers, your amplifier will run half as hot and your battery will last longer.

NOTE: *ORION amplifiers have an excellent damping factor. Damping factor is the reflected output impedance in the amplifier. The higher the damping factor in the amplifier, the less tendency for the speaker to move on its own, say when it is bumped. The amplifier controls the damping in the speaker.*

CONNECTIONS

NEVER connect any speaker to chassis ground. This will introduce ground loops that cause noise in the system and, in the case of bridging, cancels out the two-phase effect.

NEVER use twisted wire connections. Always make connections using spade connectors, insulated butt connectors, quick-disconnect connectors or solder connections. If quick-disconnects or solder connections are used, insulate the connections using shrink tubing. Do not use electrician's tape since the adhesive on such tapes tends to deteriorate with time and cause short circuits.

Do **NOT** route the speaker wires next to any power wires.

Be sure to observe speaker wire polarity. Except as shown and described in the connection diagrams in figures 1 through 15, the yellow wire is positive and the black/yellow wire is negative. Also, the orange wire is positive and the black/orange wire is negative.

SPEAKER WIRE

Use substantial wire for speaker connections. We recommend that speaker wires be at least 16 AWG. Some installers prefer the use of specially-made heavy-duty speaker wiring.

SYSTEM ADJUSTMENTS

IMPORTANT: You will get less system noise if you keep the amplifier gain as low as possible.

If you are adjusting a system containing ORION accessories, refer to the adjustment procedures contained in each applicable ORION accessory manual.

In general, make adjustments as follows:

1. Turn all power off.
2. Set the gain controls on all amplifiers to their minimum positions.
3. If an ORION 200 DAB Dual Amp Balancer is installed in the system, set both fader controls to maximum (fully clockwise).
4. Set all frequency controls on the 300 PRQ or 600 EQM Equalizers to flat response (dots in top center position).

If a 500 PMQ Parametric Equalizer is being used, set the frequency controls to the center position and set the boost/cut controls to the center position.

5. If a 600 EQM is being used, set the input gain control to minimum (fully counterclockwise).

If a 300 PRQ or 500 PMQ is being used, set both input controls to minimum (fully counterclockwise) and the VOLUME control for maximum (fully clockwise).

6. Turn on power to the amplifiers. Turn on the radio and set the VOLUME control for approximately 3/4 volume.
7. If a 600 EQM is being used, adjust the input gain control clockwise until the speakers just start to distort (clipping). If the gain control on the 600 EQM does not provide full volume, increase the gain setting of each amplifier just enough to produce clipping.

If a 300 PRQ or 500 PMQ is being used, adjust each input gain control until the speakers just start to distort (clipping). If the input gain controls on the 300 PRQ or 500 PMQ do not produce full volume, increase the gain setting of each amplifier as required to produce clipping. Decrease the setting of the VOLUME control on the 300 PRQ or 500 PMQ for desired listening level.

CAUTION: Be sure to turn off the power when disconnecting and reconnecting cables.

8. If a 200 CRX Active Crossover is installed in the system, unplug the cable from the *low output* and adjust the HIGH FREQ control to where the mid-range and highs sound best. Then plug in the *low output* cable and unplug the high output cable. Using the LOW FREQ control, adjust the lows until sound good to you. Now plug in the high output and make minor adjustments to suit your taste.

If a 300 CRX 3-Way Active Crossover is installed in the system, proceed as follows:

NOTE: Ideally, the LOW OUT should be adjusted to permit the subwoofers to reproduce all frequencies of 100 to 150 Hz and below. The HIGH OUT should be adjusted to permit the tweeters to reproduce only frequencies of about 4 kHz and above. The MID OUT should be adjusted to pass a band of frequencies of about 100 Hz to 4500 Hz. The response of the various speakers greatly affects these adjustments, however, so it is generally always better to trust your ears and simply adjust the various frequency outputs to where they sound best to you.

- a. Unplug the cables from the MID OUT and HIGH OUT connectors and adjust the LOW PASS control until the lows from the subwoofers sound good to you.
- b. Unplug the cable from the LOW OUT connector and plug in the HIGH OUT cable. Adjust the HIGH PASS control to where the highs from the tweeters sound best.
- c. Unplug the cable from the HIGH OUT connector and plug in the MID OUT cable. Adjust MID PASS controls until the instruments and voice sounds delivered by the mid-range speakers sound the fullest. Use the left-hand MID PASS control to adjust the low end and the right-hand MID PASS control to adjust the high end.
- d. Now plug in the HIGH OUT and LOW OUT cables and make minor adjustments to suit your taste.



WARRANTY

ORION products are guaranteed against defects in workmanship and materials for a period of 2 years from date of purchase. All warranty repairs are performed by ORION. This warranty period begins on the date of purchase by the original consumer.

OBLIGATION OF THE ORIGINAL

1. The dealer's Original Dated Bill of Sale must be retained as Proof of Purchase and must be presented with the defective product.
2. Warranty shipments to ORION are the responsibility of the consumer.

EXCLUSIONS:

This warranty does not cover products that have been subjected to misuse, modification, improper installation, incorrect voltage, marred or damaged housings, or improper or unauthorized repair. This is in lieu of all other warranties expressed or implied. In no event will ORION be liable for any damages resulting from equipment or any defect. This warranty gives you specific legal rights and you may have other rights which vary from state to state.

Orion Industries
9235 S. McKemy
Tempe, AZ 85284
(602) 705-5600

Other ManualsLib Projects



www.manualslib.com



www.manualslib.de



www.manualslib.es



www.manualslib.fr



www.manualslib.nl



www.manualslib.mx



www.manualslib.tech 30+ Languages